



Model CL10

Corner Load Pan Washer



The LVO CL10 corner load pan washer is easy to operate and capable of washing up to 100 pans per hour, the LVO CL10 cleans your pots, pans, bowls, or utensils with a powerful, high pressure wash. With a 7 ½ Horsepower pump and brass wash hubs, the two rotating stainless steel spray arms blast away soil for greater cleanliness. With its two doors, each with its own table, the CL10 allows for one side to be used for preparation of your soiled pans and the other for your clean pans to come out, minimizing the chance of cross contamination, while maximizing worker efficiency. The L-shaped design permits the washer to be placed in the corner, reducing the amount of floor space needed for operation.



Standard Available Racks:

Sheet Pan Rack

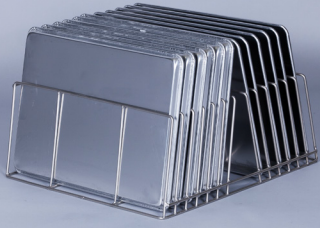

Cake Pan Rack



Utensil Basket

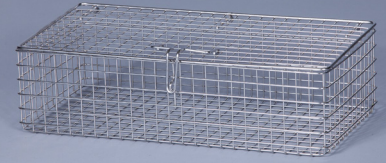

CL10 Specs:

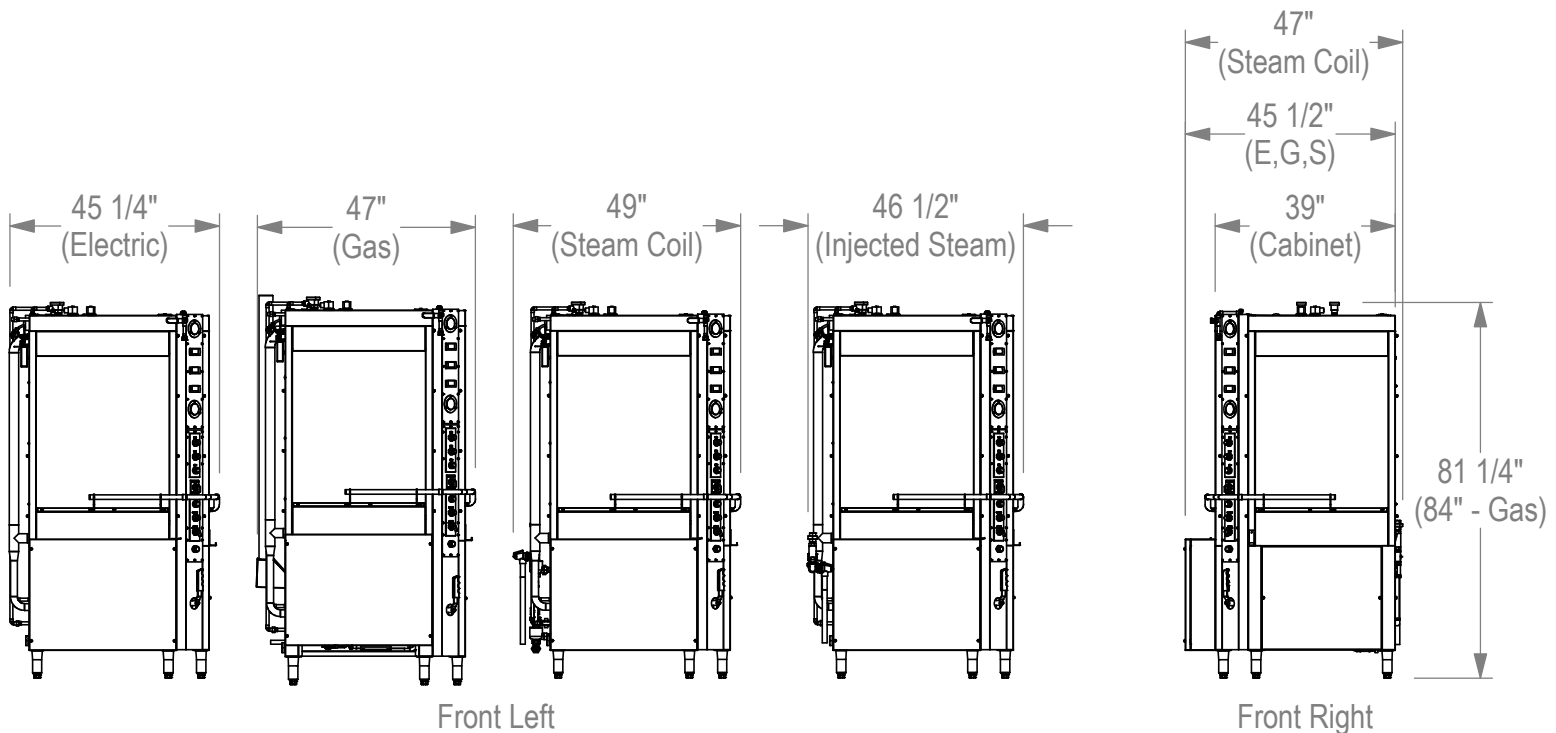

Wash Capacity: 10 Sheet Pans

Standard Voltages: 208, 230, or 460 Volt, 3 Phase, 60 Hertz

Wash Tank: Electric, Gas, Steam Coil, or Injected Steam Heat

Wash Chamber Dimensions: 28 3/4" W x 30 1/4" H x 28 3/4" L

Height with Door Open: 102 3/4" (105 1/4" for Gas Heated Machines)

Agency Listings (US & Canada): ETL (Electrical) and NSF (Sanitation)

Because of continuous improvements, specifications may change without notice. Contact manufacturer for current information.



LVO Manufacturing, Inc.

PO Box 188 • 808 North 2nd Avenue East • Rock Rapids, Iowa 51246

(800) 346-5749 • www.lvomfg.com

Feb '16