



Model FL25

Front Load Pan Washer



The LVO FL25 front load pan washer is fully automatic and capable of washing up to 250 pans per hour, the LVO FL25 cleans your pots, pans, bowls, or utensils with a powerful, high pressure wash. With a 10 Horsepower pump and brass wash hubs, the two rotating stainless steel spray arms blast away soil for greater cleanliness, while a hot water rinse ensures proper sanitizing temperature.

Easy to load and simple to operate, the front load design allows for easy access to the wash chamber, while at the same time minimizing the amount of floor space required.



Standard Available Racks:

Sheet Pan Rack

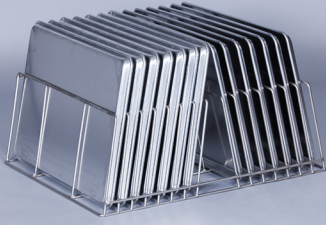

Cake Pan Rack



Utensil Basket

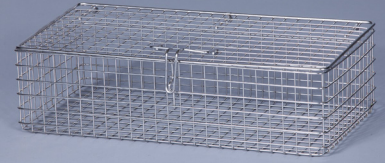

FL25 Specs:

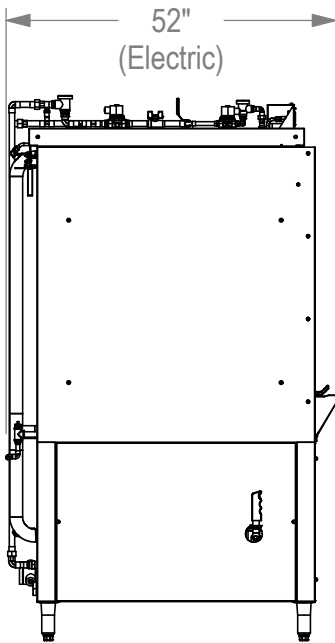

Left View

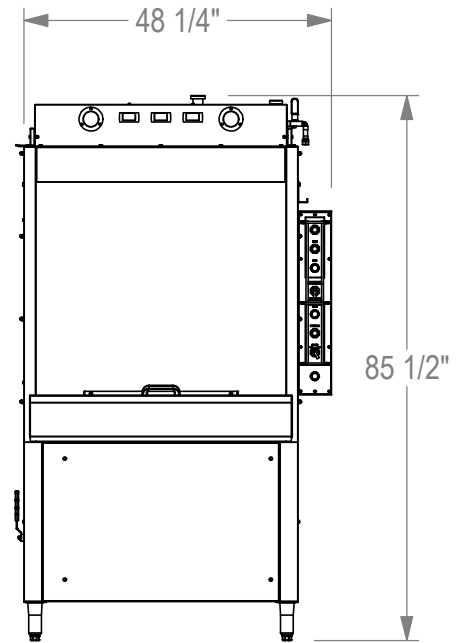
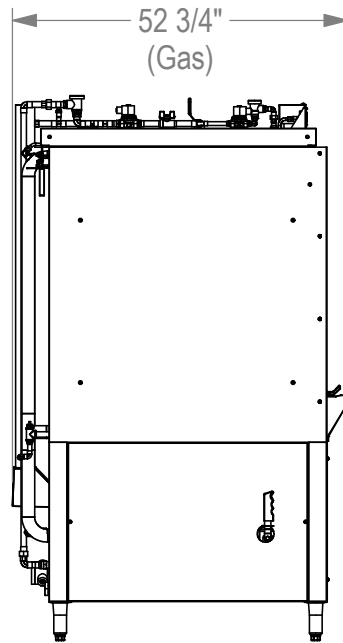

Front View

Wash Capacity: 25 Sheet Pans

Standard Voltages: 208, 230, or 460 Volt, 3 Phase, 60 Hertz

Wash Tank: Electric, Gas, Steam Coil, or Injected Steam Heat

Wash Chamber Dimensions: 39 1/4"W x 29 1/4"H x 39 1/2"L

Height with Door Open: 105 1/2"

Agency Listings (US & Canada): ETL (Electrical) and NSF (Sanitation)

Because of continuous improvements, specifications may change without notice. Contact manufacturer for current information.



LVO Manufacturing, Inc.

PO Box 188 • 808 North 2nd Avenue East • Rock Rapids, Iowa 51246

(800) 346-5749 • www.lvomfg.com

Feb '16