



Model RW1548

Pan & Rack Washer



With a large, walk in door, the LVO RW1548 Pan and Rack washer is simple to load and operate. The four rotating stainless steel spray arms and a powerful dual-stage pump design washes with a powerful, high pressure spray, followed by a sanitizing hot water rinse.

Capable of washing 480 sheet pans per hour, the RW1548's roll-in design also allows for washing your cake pans, mixing bowls, utensils, oven racks, and more.



Standard Available Racks:

Sheet Pan Rack



Cake Pan Rack



Bowl/Utensil Rack



RW1548 Specs:

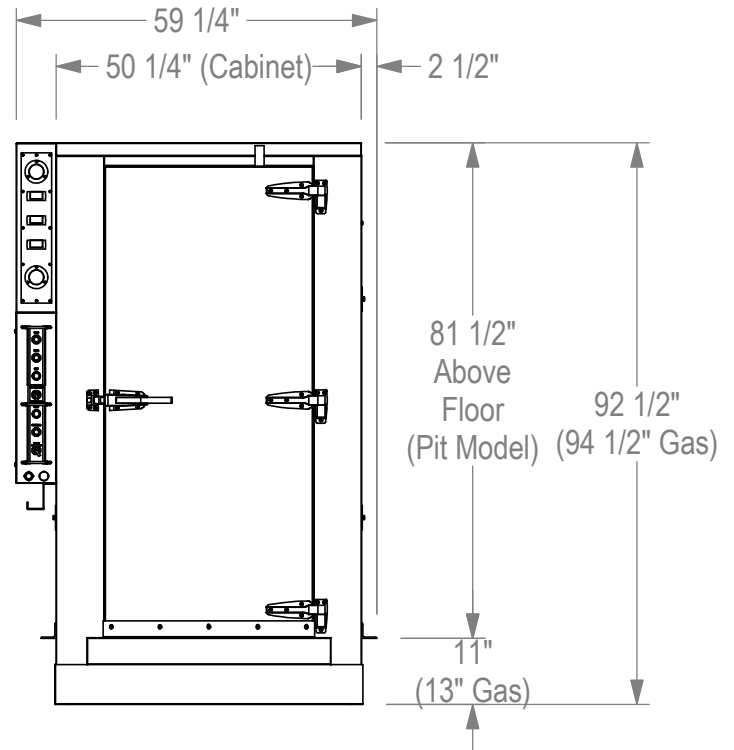
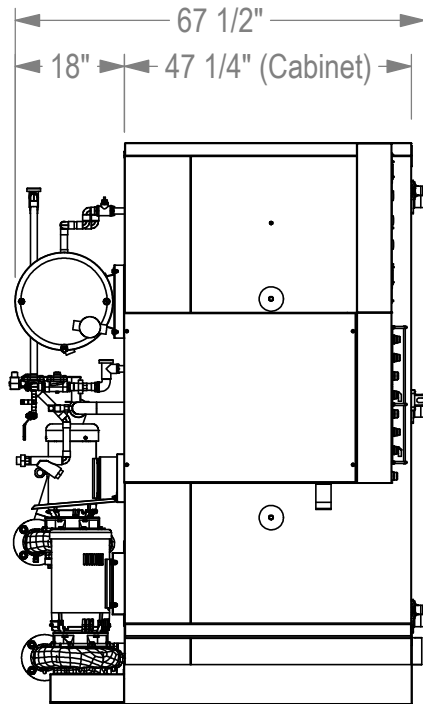

Wash Capacity: 48 Sheet Pans

Standard Voltages: 208, 230, or 460 Volt, 3 Phase, 60 Hertz

Wash Tank: Electric, Gas, Steam Coil, or Injected Steam Heat

Wash Chamber Dimensions: 31 1/2" W x 76 1/2" H x 42" L

Agency Listings (US & Canada): ETL (Electrical) and NSF (Sanitation)

Left or Right Hand Controls and Hinges Available

Because of continuous improvements, specifications may change without notice. Contact manufacturer for current information.



LVO Manufacturing, Inc.

PO Box 188 • 808 North 2nd Avenue East • Rock Rapids, Iowa 51246

(800) 346-5749 • www.lvomfg.com