



LVO Manufacturing, Inc.



FL36 Pan-Washer
Owner's Manual





LVO Manufacturing, Inc.

808 N. 2nd Avenue E., P.O. Box 188

Rock Rapids, IA 51246

www.lvomfg.com

(712) 472-3734

1-800-346-5749 Fax (712) 472-2203

Warranty

LVO Manufacturing Inc. warrants equipment manufactured by it to be free from defects in material and workmanship for a period of one (1) year from date of delivery except as noted below.

LVO will **not** be held responsible for damage or unsatisfactory performance due to negligence, accident, alteration, unauthorized repair, improper installation or startup (see owner's manual), improper application, or improper maintenance (see owner's manual).

Parts found, on factory inspection, to be defective in workmanship or materials during the warranty period will be replaced (parts and labor, not overtime), provided the Buyer returns the defective parts to LVO Manufacturing Inc. within 30 days, transportation prepaid. LVO Manufacturing Inc. will pay UPS 2nd Day Air shipping charges for parts (with the exception of excessively large or heavy items) covered on warranty if the machine is not operational.

LVO Manufacturing Inc. reserves the right to make changes in design and construction of its products without imposing any obligation upon itself toward products previously manufactured.

This warranty is in lieu of any other warranties, expressed or implied, made on the part of LVO Manufacturing Inc. who does not accept responsibility to any purchaser of its products for any representation or warranty made by dealers or salespersons beyond those herein expressed including any implied warranties of merchantability or fitness for a particular purpose.

Warranty Procedure

- 1) Locate and record the 12 digit serial number located on the upper left-hand side of the pan washer.
- 2) Gather as much information about the problem as possible.
- 3) Call LVO Manufacturing Inc. at 1-800-346-5749 and request technical service. Prior to performing any warranty work, you must call the factory for a warranty authorization number (WA-____). This warranty authorization number must be on every invoice we receive for services rendered on the machine. Without this authorization number the invoice will not be paid. The warranty number must also be included with the defective part returned.**



LVO Manufacturing, Inc.

808 N. 2nd Avenue E., P.O. Box 188

Rock Rapids, IA 51246

www.lvomfg.com

(712) 472-3734

1-800-346-5749

Fax (712) 472-2203

Table of Contents

Warranty.....	2
Table of Contents	3
FL36 Specifications	4
Electrical Data.....	5
Warnings & Cautions.....	6
Introduction.....	7
Installation Instructions.....	8
Startup Procedures	11
Sequence of Operation.....	13
Operation of Machine	14
Preventative Maintenance.....	17
Trouble Shooting – Electric Machines.....	18
Trouble Shooting – Gas Machines.....	19
Trouble Shooting – Steam Machines.....	19
Trouble Shooting Flowchart	20
Parts List	22
Drawings:	
(Drawing scales are approximate)	
General View	26
Four View – Electric	27
Four View – Gas	28
Four View – Tall Electric.....	29
Four View – Tall Gas.....	30
Door Weight & Cable Assembly	31
Bun Pan Rack.....	32
Cake Pan Rack	33
Ladder Diagram – Electric.....	34
Ladder Diagram – Gas	35



LVO Manufacturing, Inc.

808 N. 2nd Avenue E., P.O. Box 188

Rock Rapids, IA 51246

www.lvomfg.com

(712) 472-3734

1-800-346-5749

Fax (712) 472-2203

FL36 Specifications

Overall Dimensions

Width – 83 ½”

Depth – 45 ¾”

Height – 84 ½” (93 ½” for tall units)

Height with door open – 104” (122” on tall units)

Door opening – 73” wide x 28 ½” high (37 ¾” high for tall units)

Hot Water System

1” hot water supply required, union provided

140°F water required at the machine

126 GPH at 20 PSI (10 ½ gal/cycle x 12 cycle/hr)

Rinse booster: (2) 9 kW heating element in a 15 gallon rinse tank OR

½” steam coil in a 15 gallon rinse tank (Recirculating Steam Only)

Full Load Amps

	208 Volt	230 Volt	460 Volt
Electric	142.0	128.4	65.2
Gas/Injected Steam	92.0	83.2	42.6
Recirculating Steam	42.0	38.0	20.0

Gas System (Gas Machines Only)

½” gas supply

Natural: 7” W.C. minimum inlet, 6” W.C. main manifold – 90,000 BTU

Propane: 11” W.C. minimum inlet, 10” W.C. main manifold – 90,000 BTU

4” stainless steel chimney on back of machine

Steam System (Steam Models Only)

¾” steam line, 10-15 PSI 41 lbs/hr average – Injected

72 lbs/hr average – Recirculating

Wash System

15 Hp pump recirculates approximately 240 GPM @ 55 PSI

Heat: Electric – (2) 9 kW heating element

 Gas – (4) 22,500 BTU rated infrared burners – 90,000 BTU total

 Injected & Recirculating Steam – 10 to 15 PSI, 41 lbs/hr average

70 gallon wash tank

1 ½” copper drain

8” steam exhaust vent companion flange

(Requires PVC, CPVC, or stainless steel field installed duct)



LVO Manufacturing, Inc.

808 N. 2nd Avenue E., P.O. Box 188

Rock Rapids, IA 51246

www.lvomfg.com

(712) 472-3734

1-800-346-5749

Fax (712) 472-2203

Electrical Data

Electrical Data for model FL36 – Electric

	208 Volt	230 Volt	460 Volt
Pump Motor	40.0	36.0	18.0
Control Circuit	2.0	2.0	2.0
Wash Heater (two 9 kW)	50.0	45.2	22.6
Rinse Heater (two 9 kW)	<u>50.0</u>	<u>45.2</u>	<u>22.6</u>
Total Running Current	142.0	128.4	65.2
Exhaust Fan (Opt.)	2.0	2.0	1.0

Electrical Data for model FL36 – Gas or Injected Steam

	208 Volt	230 Volt	460 Volt
Pump Motor	40.0	36.0	18.0
Control Circuit	2.0	2.0	2.0
Rinse Heater (two 9 kW)	<u>50.0</u>	<u>45.2</u>	<u>22.6</u>
Total Running Current	92.0	83.2	42.6
Exhaust Fan (Opt.)	2.0	2.0	1.0

Electrical Data for model FL36 – Recirculating Steam

	208 Volt	230 Volt	460 Volt
Pump Motor	40.0	36.0	18.0
Control Circuit	<u>2.0</u>	<u>2.0</u>	<u>2.0</u>
Total Running Current	42.0	38.0	20.0
Exhaust Fan (Opt.)	2.0	2.0	1.0

*Electrical Supply to the machine should **exceed** the figures by the amount required by local codes.*

Note: Changing the voltage of the machine in the field requires different heating elements. Contact the factory if this situation arises.



LVO Manufacturing, Inc.

808 N. 2nd Avenue E., P.O. Box 188

Rock Rapids, IA 51246

www.lvomfg.com

(712) 472-3734

1-800-346-5749 Fax (712) 472-2203

Warnings & Cautions

General Warnings and Cautions:

1. Service work on the machine should be done by either a factory representative or qualified local service company. **Contact the factory if the machine is under warranty.**
2. Failure to follow the cleaning guidelines described in this manual will damage the machine and will void the warranty.

Gas Model Warnings and Cautions:

1. Installation must conform to local codes and the National Fuel Gas Code, ANSI Z223.1.
In Canada: Installation must be in accordance with CGA Standard CAN/CGA-B149.1, Natural Gas Installation Code or CAN/CGA-B149.2, Propane Installation Code.

FOR YOUR SAFETY: DO NOT STORE OR USE GASOLINE OR OTHER FLAMMABLE VAPORS OR LIQUIDS IN THE VICINITY OF THIS OR ANY OTHER APPLIANCE.



WARNING: IF YOU SMELL GAS, SHUT OFF THE GAS SUPPLY TO THE APPLIANCE, EXTINGUISH ANY OPEN FLAME, AND TEST ALL JOINTS WITH A SOAP SOLUTION. IF ODOR PERSISTS, CALL YOUR GAS SUPPLIER IMMEDIATELY.



AVERTISSEMENT: SI UNE ODEUR DE GAZ EST DÉCELÉE, COUPER L'ALIMENTATION EN GAZ DE L'APPAREIL, ÉTEINDRE TOUTES LES FLAMMES ET VÉRIFIER TOUS LES RACCORDS À L'AIDE D'UNE SOLUTION SAVONNEUSE. SI L'ODEUR PERSISTE, AVERTIR IMMÉDIATEMENT LE FOURNISSEUR DE GAZ.

2. Instructions should also be posted in a prominent location describing what to do in the event that the smell of gas is detected in the vicinity of the machine. (This information can be obtained from your local gas supplier).
3. Do not obstruct the flow of ventilation and combustion air to the machine.
4. Gas model pan washers are equipped with an electronic ignition that automatically lights the burners when the power switch is turned to the "ON" position and there is enough water in the machine. To shut the burners off, the power switch should be turned to the "OFF" position.



LVO Manufacturing, Inc.

808 N. 2nd Avenue E., P.O. Box 188

Rock Rapids, IA 51246

www.lvomfg.com

(712) 472-3734

1-800-346-5749

Fax (712) 472-2203

Introduction

This manual should be read and understood by everyone involved with the installation and operation of the pan washer. Keep this manual in a safe place for future reference. Extra copies or replacement copies can be purchased from the manufacturer.

Service work on the machine should be done by either a factory representative or qualified local service company. **Contact the factory if the machine is under warranty.**

The LVO pan washer is designed for use in bakeries, restaurants, schools, hospitals, and hotels, to clean pots, pans, bowls, and utensils. LVO pan washers are constructed of 14 gauge stainless steel (cabinets) and 12 gauge stainless steel (framework). The interior piping, rinse system, wash arms, and screens are stainless steel. Because of its sturdy construction, it will deliver years of powerful, thorough cleaning.

The machine is equipped with a heating element in the rinse tank to boost the rinse water to a sanitizing 180°F at the inlet to the machine. A rinse tank heated with recirculated steam is an option available on some models.

The wash tank on electric models incorporates two 9 kW electric heating elements for heating the wash water. The gas models use a series of (4) 22,500 BTU infrared burners. Steam models use either a direct injection system or a recirculated steam heating coil.

The pump recirculates wash water at approximately 55 pounds per square inch of pressure.

Each machine is equipped with two safety switches. The first is a low water cut-off, which shuts the machine off when the water level in the wash tank falls below the required level. The other safety device is a door switch, which prevents the machine from operating when the door is not completely closed. An electrical schematic for your machine is posted inside the control box cover.

Detergent Feeders

This machine must be operated with an automatic detergent feeder, which is supplied by the customer, including a visual means to verify that detergent is delivered or a visual or audible alarm to signal that detergent is not available for delivery. Power for the feeder can be provided by the pump supply connection in the control panel. See feeder equipment manual for additional information.



LVO Manufacturing, Inc.

808 N. 2nd Avenue E., P.O. Box 188

Rock Rapids, IA 51246

www.lvomfg.com

(712) 472-3734

1-800-346-5749

Fax (712) 472-2203

Installation Instructions

Step 1 READ: Read and understand these instructions thoroughly before attempting any part of the installation process.

 **WARNING: Not following these instructions may void warranty, cause damage to the equipment and/or cause injury to anyone involved in the installation or operation of this machine.**

A copy of the installation instructions and start-up procedure is printed on the sheet attached to the side of the machine. EVERYONE involved with the installation must be familiar with all aspects of the installation procedure.

Step 2 POSITIONING: The factory recommends leaving as much room as possible around the machine for future service work. No less than 16" should be allowed along the sides of the machine (36" for side with control box), and no less than 12" between the rear of the machine and the wall. Extra room around the machine will facilitate cleaning the washer area.

Step 3 UNCRATING: Leave the machine fully crated until the washer is placed in the location where it is to be installed. After the washer is uncrated, remove the banding that holds the door weight stationary on the back of the machine. This will allow the door to open. Inside you will find the accessories for the machine. Among these will be the fan (if ordered) and the legs. Remove the machine from the pallet, install the legs, and level the machine. The legs are adjustable by turning the small end one way or the other.

Step 4 DRAIN: Provisions for the drain should be made next. The pan washer has a copper drain located as shown on the drawings (see specifications page for drain size). The drain should be plumbed according to local code. Local ordinance may require a grease trap, vent, and/or a floor sink. If required, these should be installed before the machine is installed. It is strongly recommended that unions be used to allow the machine to be easily moved. Failure to do so may void the warranty.

Step 5 WATER SUPPLY HOOK-UP: The factory recommends 140°F hot water at the machine (see specifications page for water line size). This may require a dedicated water heater for the pan washer. If hard water is present, the manufacturer recommends installing a water softener or calcium filter. Hard water deposits will shorten the life of many of the components on the pan washer, resulting in higher maintenance costs. Please note that a union is installed at the point of hook-up (see drawings). This will allow the machine to be moved for service and cleaning. The customer must furnish a shut-off valve on the supply side of the union. This shut-off should be easily accessible to the operator of the machine. Additionally, if the



LVO Manufacturing, Inc.

808 N. 2nd Avenue E., P.O. Box 188

Rock Rapids, IA 51246

www.lvomfg.com

(712) 472-3734

1-800-346-5749

Fax (712) 472-2203

machine is located a long distance from the water main, it may be necessary to supply a larger line to the machine to insure proper water pressure and flow for the machine to operate correctly.

Step 6 STEAM VENT: The machine is equipped with a collar for 8” duct work as shown on the drawings. This duct should be directly vented to the outside of the building. DO NOT vent into a wall, attic, or any other concealed space of the building, and avoid horizontal runs of duct.

The factory recommends 8” plastic pipe or stainless steel duct for the vent. If stainless steel is used, the duct work should be installed with reverse joints so that the condensate inside the vent can drain back into the machine without leaking, and all seams should be sealed with silicone sealant.

Generally, the machine ships with a 700 cfm, ½ Hp (¾ Hp on 50 Hz machines) squirrel cage fan.

The fan and included adapter should be mounted and sealed with silicone directly to the flange on the top of the machine before the ductwork is installed. The ductwork attaches directly to the side discharge of the fan. Wire and flex conduit are provided to wire the fan directly into the control panel. A dedicated circuit breaker and contactor for the fan are provided. The fan is controlled by a timer and runs for a short time at the end of the cycle, and when the door of the machine is open.

Note: Consult the factory before connecting any fan not supplied with the machine.

While the machine is designed to be directly connected to a vent, local or state codes may require a hood to be installed. Always check the local regulations prior to installing the vent.

Step 7 ELECTRICAL CONNECTIONS: The electrical connection to the machine should be made by a qualified electrician. All steps should be taken to insure that the supply voltage to the machine is the same as the rated voltage of the machine. Also, check that sufficient amperage is supplied to the machine (see specifications page for ratings).

A main power shut-off, supplied by the customer, must be installed near the machine in a place easily accessible by anyone operating or servicing the machine. The line from the main shut-off to the machine should be watertight flex conduit. The factory strongly recommends that a few extra feet be used to allow the machine to be moved if necessary. The wire used to supply the machine must be heavy enough to carry the amperage load of the machine.



LVO Manufacturing, Inc.

808 N. 2nd Avenue E., P.O. Box 188

Rock Rapids, IA 51246

www.lvomfg.com

(712) 472-3734

1-800-346-5749 Fax (712) 472-2203

The first connection should be the main ground to the grounding lug at the lower right hand corner of the control panel. Next, the hook-up can be made to the main power block.

Once the hook-up is complete, the circuit breakers in the control box of the washer must be checked to make sure they are in the “OFF” position. The main switch on the wall can then be turned on to power the machine.

Step 8 GAS CONNECTION (Gas Machines Only): A certified gas technician is required for the hook-up and final adjustments of the burners. This is necessary to insure proper inlet and manifold pressure for the gas machines (see spec page for gas pressure settings).

Verify the type of gas supply to be used, either natural or LP, and make sure the marking on the gas data plate agrees with that of the supply. The gas line hook-up must be made with a union at the location shown on the gas machine drawing (see spec page for gas line size). This line must have a shut-off valve (supplied by the customer) installed near the machine and accessible by anyone operating or servicing the machine.

A 4” stainless steel gas chimney runs up the back of the machine. A draft diverter is included with the machine (shipped inside the machine with the other accessories). The draft diverter must be installed on top of the factory installed chimney. The Type B gas flue can then be continued to the outside of the building per local codes.

The initial start-up of the burners should not be done until the start-up procedures for the machine on the following pages have been completed.

Step 9 STEAM CONNECTION (Steam Machines Only): A steam line is required to supply the steam injector or recirculated steam heat exchanger coil (see spec page for size of steam line). A strainer is already built into the machine but a union will be required in the supply line (supplied by the customer). The specification sheet above lists the rated pressure and average steam consumption rate for the machine.



LVO Manufacturing, Inc.

808 N. 2nd Avenue E., P.O. Box 188

Rock Rapids, IA 51246

www.lvomfg.com

(712) 472-3734

1-800-346-5749

Fax (712) 472-2203

Startup Procedures



Warning: These instructions must be followed or damage to the machine will result.

Step 1: Close drain valve. See drawings for location.

Step 2: With the circuit breakers in the control panel of the machine in the “OFF” position and the main power supply to the machine connected, the **ON-OFF switch** on the button panel can be turned to the “ON” position. Then wait approximately 5 seconds for the machine controller to power up.

Note: The amber power light will not turn on until there is sufficient water in the machine.

Step 3: Fill the machine by pressing the **Auto Fill** button. The machine will continue to fill for 90 seconds past the point where the low water protection device is energized, turning on the power light and temperature controllers. **The machine is equipped with a low water protection device and will not run without sufficient water in the wash tank.**

Note: The machine has a door switch and will not operate with the door partially open.

Step 4: With the machine full of water and with the door closed, press the start button and let the machine go through a complete cycle. The timers in the control panel will go through their sequence, lighting the wash and rinse lights on the front of the machine. The cycle is complete when the red light goes off and the amber light stays on. The pump will not run at this time because the pump circuit breaker in the control panel is in the “OFF” position.

Step 5: Repeat **Step 4** at least two times or until water can be heard spraying out of the rinse nozzles. This ensures that the rinse tank is full of water before the heating element is energized.

Step 6: All circuit breakers in the control panel can now be switched to the “ON” position. This will energize the heating system in the wash and rinse tanks.

Step 7: Check the pump for proper rotation by pressing the start button and observing the wash pressure gauge on the front of the machine for 5 to 10 seconds. Then press the stop button. The wash pressure should be 45-60 psi. If the pressure is erratic and only rises to about 20 psi, the pump is running backwards. The pump will also have a noticeable growl when running backwards. Disconnect power to the machine and reverse the outside two wires that feed the power block in the control panel. Reconnect power and run the pump again to confirm that it is operating correctly.



LVO Manufacturing, Inc.

808 N. 2nd Avenue E., P.O. Box 188

Rock Rapids, IA 51246

www.lvomfg.com

(712) 472-3734

1-800-346-5749 Fax (712) 472-2203

Step 8: With the power on, the wash and rinse heating systems should be checked. The rinse tank should take 5 to 10 minutes to reach 200°F and the wash should take approximately 40 to 45 minutes to reach 160°F. The times will vary depending on the temperature of the incoming water. **Note:** The rinse manifold gauge measures the temperature of the rinse water just before it enters the machine. Therefore, this temperature reading is only accurate while the machine is rinsing.

If the machine is not reaching temperature, check to make sure that all the breakers in the control panel are in the “ON” position. If the wash tank is gas heated, make certain the main gas valve is open. During initial start-up, gas machines may have to be turned on and off several times to bleed the air out of the gas lines. Wait about a minute after turning the machine off before turning it back on. If the machine still does not appear to be heating up properly, call LVO Manufacturing at 1-800-346-5749.

Step 9: Set the rinse pressure by changing the pressure adjustment valve located on the top of the machine. The pressure should be set at 20 psi on the rinse gauge **while the machine is rinsing.** Variations in building water pressure may require the pressure to be increased or decreased from its factory setting.

Step 10: Machines are equipped with an **Auto Fill** and have a timer in the electrical panel that controls the fill valve. Adjust the timer so that the machine fills to the overflow tube (or until water just begins to run out of the machine’s drain) when the **Auto Fill** button is pressed.

Step 11: If the machine is equipped with the fan option, (see Step 6 in the Installation Instructions for a description of the fan option) verify that it is rotating in the correct direction. If the fan is blowing into the machine rather than out the vent, switch the two outside wires on the three phase connection in the control panel. Recheck to confirm proper rotation.

Step 12: Replace all covers and peel off the plastic protective coating, tape, etc. from the machine that may have been used to prepare the machine for shipping.



LVO Manufacturing, Inc.

808 N. 2nd Avenue E., P.O. Box 188

Rock Rapids, IA 51246

www.lvomfg.com

(712) 472-3734

1-800-346-5749

Fax (712) 472-2203

Sequence of Operation

- Power switch is switched “ON”
- Control panel logic control is energized
- Fill button energizes the fill solenoid
- Low water safety switch closes terminals 1 and 4 in the control panel if there is sufficient water in the wash tank
- Amber indicator light comes on
- Wash and rinse temp controls are energized
- Temp controls energize wash and rinse heating systems
- Door safety switch is energized
- Stop and Start buttons are energized
- Start button is pushed energizing the internal timing functions of the logic control
- Red indicator light is energized
- Wash timer (Light, Medium, or Heavy) starts, energizing the pump contactor for set amount of time
- Wash time runs out energizing the rest timer
- After set amount of rest time, the rinse timer starts, energizing the rinse solenoid valve and clear indicator light
- If the machine is equipped with the exhaust fan option, the fan timer runs for the set time when the rinse cycle is completed
- After the rinse timer (or optional fan timer) has timed out, all timers are reset, and the red indicator light is de-energized



LVO Manufacturing, Inc.

808 N. 2nd Avenue E., P.O. Box 188

Rock Rapids, IA 51246

www.lvomfg.com

(712) 472-3734

1-800-346-5749 Fax (712) 472-2203

Operation of Machine

Initial Daily Startup

1. Check if the inside of the machine has been properly cleaned since its last use. If not, clean the machine (refer to **Final Clean-Up** on the following page for cleaning information).
2. Make sure scrap tray screens and the pump inlet screens are in place.
WARNING: Do not operate washer without all screens in place.
3. Close the drain valve.
4. Turn power switch to “ON” position, allow approximately 5 seconds for the internal logic controller to power up, and push the **Auto Fill** button to fill the unit.
5. Allow wash and rinse temperatures to come up to recommended levels.
6. While machine is warming up, the first load can be prepared and placed in the machine. If the pans are excessively dirty, they should be pre-soaked and scraped before being placed in the rack. Pan preparation will reduce the need to change the wash water and will speed-up the entire washing process. The correct manner for loading the racks is illustrated on the drawings later in this manual.
7. Once the machine has reached the recommended temperatures, detergent should be added to the wash water. Detergent should be used according to the recommendations of the chemical supplier. A non-suds detergent is necessary and local water conditions should be considered when selecting the concentration of the detergent. An automatic soap dispenser should be installed at the job site by the chemical supplier. There should be a visible or audible means of determining detergent delivery. If they have any questions concerning the installation of their dispenser to the LVO pan washer, they can call the factory for advice (800-346-5749).
8. The rack of pans can now be placed in the machine. The rack should be centered in the machine to subject the pans to the full force of the spray arms.

WARNING: Loose items and glassware should not be put in the washer. The high pressure wash cycle will damage them and potentially the machine.

Bowls or buckets can be washed by placing them upside down on the main support rack.

The utensil basket is to be used to contain smaller items such as paddles, whisks, scrapers, etc.

CAUTION: When loading the machine make sure that nothing will obstruct the path of the wash arms. This will avoid damage to the machine and to the items being washed.

When loading bowls, pans, or buckets into the machine make sure they are loaded in a manner that will allow the wash water to drain out of them.



LVO Manufacturing, Inc.

808 N. 2nd Avenue E., P.O. Box 188

Rock Rapids, IA 51246

www.lvomfg.com

(712) 472-3734

1-800-346-5749

Fax (712) 472-2203

9. The machine cycle is completely automatic with adjustable wash, rest, and rinse timers. The timers are located in the control panel and are factory set to the following recommended values:

Wash: Light	3 Min
Medium	5 Min
Heavy	7 Min
Rest:	20 Sec
Rinse:	40 Sec
Fan (Optional)	30 Sec

Select length of wash (Light/Medium/High) with the 3 position selector on the button panel and push the green start button to initiate the wash cycle. The red indicator light will come on. At the end of the wash cycle, the red light will stay on and the 20 sec rest will begin. The rest period allows the wash water and suds to drain from the pans. After the rest cycle, the rinse cycle begins. During the rinse cycle, the clear indicator light will come on. If the machine is equipped with a fan timer (see above for a description of the fan), the fan will start after the rinse is finished. After the rinse or fan cycle is finished, the red light will go off. The cycle is now complete. The amber power light will stay on as long as the power switch is in the "ON" position and there is enough water in the machine.

10. Throughout the day as the machine is being used, the scrap tray screens should be periodically removed from the machine, dumped out, washed out in the sink and replaced in the machine.

Final Cleanup

At the end of each day's use, the operator of the machine must clean the machine according to the following procedure:

1. Check and clean any plugged wash nozzles. Use a piece of wire to push any obstruction out of the nozzle into the wash arm. When all of the nozzles have been cleared, close the door; push the start button running the machine for a few seconds to blow the debris out of the wash arms. Push the red "STOP" button. If necessary, the wash arm assembly can be removed by pulling out the grip ring pin and sliding the assembly out of the hub.
2. Turn the machine off and open the drain valve.
3. Remove the scrap trays, dump them out, and wash them off in the sink.
4. Spray down the inside of the machine.
5. Brush off the heating element (electric models) and anywhere that doesn't come clean from spraying with the hose.



LVO Manufacturing, Inc.

808 N. 2nd Avenue E., P.O. Box 188

Rock Rapids, IA 51246

www.lvomfg.com

(712) 472-3734

1-800-346-5749 Fax (712) 472-2203

Note: On electric models, brushing the element is very important in prolonging the life of the element.

6. Check and clean the rinse nozzles.
7. Spray down the inside of the machine again.
8. Remove the pump inlet screen and clean it thoroughly in the sink.

Note: While removing the screen be careful not to allow any debris to fall into the pump inlet opening.

9. Replace the pump inlet screen and the scrap tray screens.
10. Close the drain and leave the machine empty of water until it is to be used again.



LVO Manufacturing, Inc.

808 N. 2nd Avenue E., P.O. Box 188

Rock Rapids, IA 51246

www.lvomfg.com

(712) 472-3734

1-800-346-5749

Fax (712) 472-2203

Preventative Maintenance

- Turn off power and drain machine, making sure it drains freely.
- Check machine for general cleanliness. Make sure the pump screen and scrap trays are clean and properly in place. Wash heating elements (electric models only) must be cleaned on a daily basis for proper operation. Check for plugged wash and rinse nozzles. If necessary, the entire wash arm assembly can be removed by pulling out the grip ring pin and sliding the assembly out of the hub. These items are part of the daily maintenance schedule.
- Check for excessive play in the hub/wash arm assemblies. Excessive wear can affect the wash pressure and shorten the life of some hub components. Hub repair kits are available from the factory.
- Close drain valve and fill machine, making sure drain does not leak (some water may initially run out of the drain through the overflow). Run through a Light, Medium, and Heavy wash cycle, checking for proper timer operation.
- Check if Power, Wash, and Rinse lights are working.
- Check if pump pressure during wash cycle is within recommended range (45-60 psi).
- Check if rinse pressure is approximately 20 psi. Note: This must be checked during rinse cycle for accurate reading.
- Make sure steam exhaust fan is working properly. See **Step 6** in the Installation Instructions for proper operation.
- Allow machine to heat up to recommended temperatures, making sure the temperature controls are operating properly. Wash temperature and Rinse Tank temperature should be noted at this time. The rinse water temperature gauge is accurate only during rinse cycle and should be checked while machine is rinsing.
Note: If a qualified technician is available, current readings for heating elements should be taken to ensure they are heating properly.
- Machines with slide-up doors, door cables and connections should be inspected for damage or excessive wear and replaced if necessary. Make sure cable pulleys turn freely and door switch is still adjusted properly.
- Pump motor(s) should be greased occasionally depending on usage. Once or twice yearly should be sufficient under normal use.

Note:

Items above marked ● are easily identified visually and should be checked on a daily basis. Other items should be checked periodically, depending on usage.

Time required for complete inspection may vary, depending on wash timer settings, heat up time, etc. One to two hours is a reasonable amount of time unless problems are encountered that need attention. If any problems or questions arise, call the factory for assistance.



LVO Manufacturing, Inc.

808 N. 2nd Avenue E., P.O. Box 188

Rock Rapids, IA 51246

www.lvomfg.com

(712) 472-3734

1-800-346-5749 Fax (712) 472-2203

Trouble Shooting – Electric Machines

<u>Problem</u>	<u>Cause</u>	<u>Cure</u>
Machine won't run	No power to machine Not enough water Door open	Check building power supply Fill machine until overflowing Close door tightly
Wash pressure too high	Nozzles plugged	Remove debris from nozzles
Wash pressure too low	Pump running backwards Pump screen clogged Excessive suds Missing wash nozzles	See Installation Instructions See Cleaning Instructions Change soap or use less Replace nozzles or wash arm
Wash temperature too low	Thermostat set too low Wash element blown	Adjust wash thermostat* Replace wash heating element
Rinse temperature too low	Thermostat set too low Water supply too cold Rinse element blown	Adjust rinse thermostat* Set building hot water at 140°F Replace rinse heating element
No rinse water	Nozzles plugged Solenoid valve stuck Rinse strainer clogged	See Cleaning Instructions Clean or replace solenoid valve Clean pressure regulator/strainer
Rinse does not shut off	Rinse solenoid stuck open	Clean or replace solenoid valve
Utensils not clean	Wash time too short Water too hard Wash temperature too low Detergent problem Improper stacking of utensils	Use longer wash Install softener Adjust thermostat* Consult chemical supplier See racking instructions

* **WARNING:** Do not set rinse thermostat above the boiling point of water. The boiling point of water decreases with increased elevation at approximately 2°F per 1000 ft of elevation.



LVO Manufacturing, Inc.

808 N. 2nd Avenue E., P.O. Box 188

Rock Rapids, IA 51246

www.lvomfg.com

(712) 472-3734

1-800-346-5749

Fax (712) 472-2203

Trouble Shooting – Gas Machines

(Same as electric model except for the following)

Low wash temperature:

1. Check temperature control set point.
2. Check switches, fuses, and breakers that control the burners.
3. Check to be sure electrical power and gas supply have not been interrupted to the burners.
4. Check that all shut-off valves in the gas line and main gas valve are in the “OPEN” position.
5. Reset ignition control & try again. To reset control:
 - a. Turn On-Off switch to “Off” position.
 - b. Wait one minute, turn switch to “On” position.
6. If above steps do not light the main burner, call your local gas appliance service technician. Provide the person working on the machine with the ignition system information included with this owner’s manual.



WARNING: DO NOT ATTEMPT TO LIGHT BURNER MANUALLY

Trouble Shooting – Steam Machines

(Same as electric model except for the following)

Low wash temperature:

1. Check temperature control set point.
2. Check boiler pressure.
3. Check to be sure electric signal is being sent to the steam solenoid.
4. Verify that the strainer in the steam line is open.
5. Check steam solenoid.

WARNING: Do not set rinse thermostat above the boiling point of water. The boiling point of water decreases with increased elevation at approximately 2°F per 1000 ft of elevation.



LVO Manufacturing, Inc.

808 N. 2nd Avenue E., P.O. Box 188

Rock Rapids, IA 51246

www.lvomfg.com

(712) 472-3734

1-800-346-5749 Fax (712) 472-2203

Trouble Shooting Flowchart

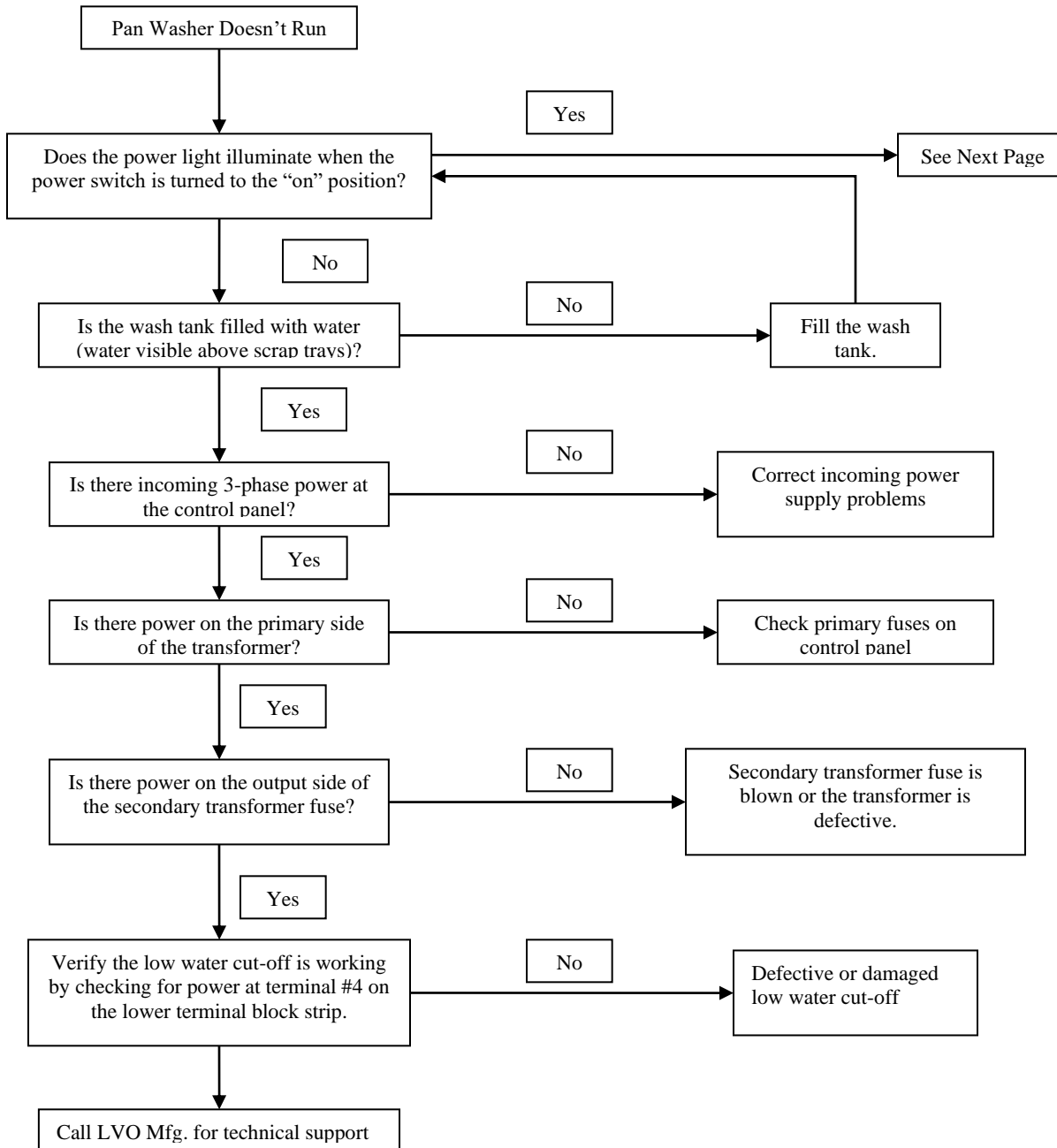



LVO Manufacturing, Inc.

808 N. 2nd Avenue E., P.O. Box 188

Rock Rapids, IA 51246

www.lvomfg.com

(712) 472-3734

1-800-346-5749

Fax (712) 472-2203

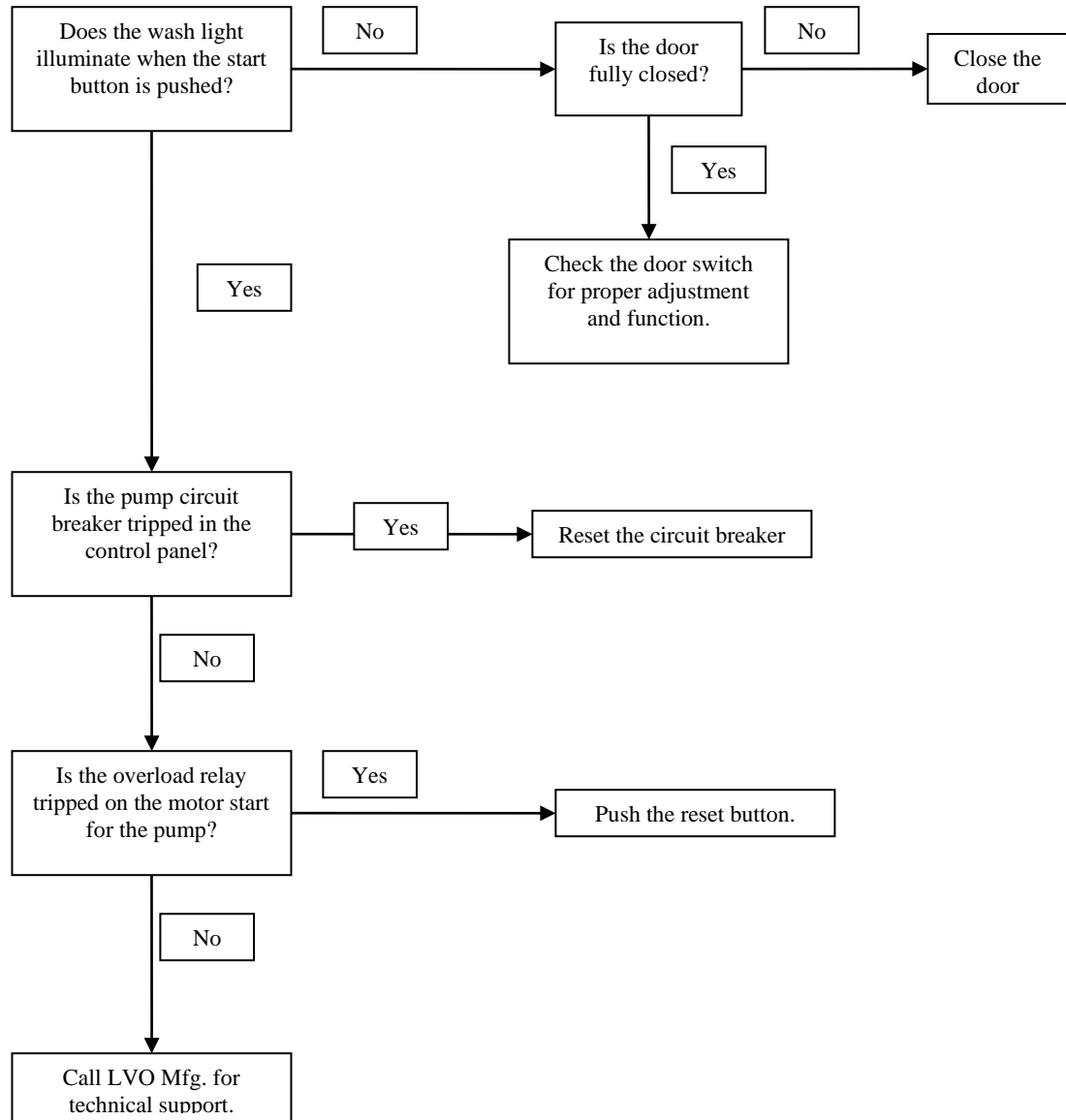



LVO Manufacturing, Inc.

808 N. 2nd Avenue E., P.O. Box 188

Rock Rapids, IA 51246

www.lvomfg.com

(712) 472-3734

1-800-346-5749 Fax (712) 472-2203

Pan Washer Replacement Parts List

FL36

Miscellaneous Parts

<u>Part Number</u>	<u>Description</u>
517-5001	Adjustable Leg
517-5022	Door Handle
106-2111	Pump Screen
101-2002	Scrap Tray
106-2103	Rinse Tank – Electric Heat (Threaded Heater)
106-2145	Rinse Tank – Electric Heat (Clamp Heater)
106-2126	Rinse Tank – Recirculating Steam
512-5011	American Fan with Squirrel Cage
512-5015	Squirrel Cage for American Fan
512-5008	½ Hp Motor for American Fan
130-2056	American Fan Assembly with Motor

Gauge Parts

<u>Part Number</u>	<u>Description</u>
509-5153	Temperature Control
509-5133	Temperature Display – Rinse Manifold
509-5155	Temperature Sensor
509-5060	Pressure Gauge, 2 ½”



LVO Manufacturing, Inc.

808 N. 2nd Avenue E., P.O. Box 188

Rock Rapids, IA 51246

www.lvomfg.com

(712) 472-3734

1-800-346-5749

Fax (712) 472-2203

Heating Parts

<u>Part Number</u>	<u>Description</u>
509-5004	Wash & Rinse Element, 9 kW 208 Volt – Threaded
509-5005	Wash & Rinse Element, 9 kW 230 Volt – Threaded
509-5006	Wash & Rinse Element, 9 kW 460 Volt – Threaded
509-5220	Wash & Rinse Element, 9 kW 208 Volt – Clamp
509-5221	Wash & Rinse Element, 9 kW 230 Volt – Clamp
509-5224	Wash & Rinse Element, 9 kW 460 Volt – Clamp
507-5007	2 ½” Sanitary Clamp Gasket for Heaters
507-5001	2 ½” Sanitary Clamp for Heaters
509-5132	High Limit Thermostat
509-5016	Infrared Burner
509-5026	½” Steam Injector – Injected Steam
510-5164	½” Steam Solenoid
509-5050	Direct Spark Ignition Gas Valve
509-5051	Direct Spark Ignition Control Module
509-5052	Spark Igniter
509-5053	Flame Sensor
509-5054	Ignition Cable, 36”
509-5094	5”-7” Gas Regulator Conversion Kit
509-5097	7”-11” Gas Regulator Conversion Kit
511-5127	Sensor Wire
509-5099	LP Gas Orifice, #54
509-5100	Natural Gas Orifice, #45

Drain System Parts

<u>Part Number</u>	<u>Description</u>
510-5145	1 ½” NPT Ball Valve



LVO Manufacturing, Inc.

808 N. 2nd Avenue E., P.O. Box 188

Rock Rapids, IA 51246

www.lvomfg.com

(712) 472-3734

1-800-346-5749 Fax (712) 472-2203

Wash System Parts

<u>Part Number</u>	<u>Description</u>
103-2025	Hub Assembly
103-2049	Hub Repair Kit
510-5127	15 Hp Pump Motor, 208-230/460 Volt
510-5283	15 Hp Pump & Motor Assembly
510-5101	15 Hp Pump Impeller (Berkeley Pump)
510-5096	Pump Seal Kit (Berkeley Pump)
510-5092	Pump Motor Shaft Sleeve (Berkeley Pump)
510-5094	Extension Bracket Gasket (Berkeley Pump)
510-5253	15 Hp Pump Impeller (Franklin Pump)
510-5260	Pump Seal Kit (Franklin Pump)
510-5265	Pump Motor Shaft Sleeve (Franklin Pump)
510-5270	Extension Bracket Gasket (Franklin Pump)
519-5038	Hub Grip Ring Pin
106-2121	Upper Wash Arm Assembly
106-2122	Lower Wash Arm Assembly

Rinse & Fill System Parts

<u>Part Number</u>	<u>Description</u>
510-5011	Rinse Nozzle, 1/4"
510-5185	1" 24VAC Solenoid
510-5052	1" Vacuum Breaker
510-5009	1/2" Ball Valve
514-5057	3/8" x 12' Spray Hose
519-5043	Brass Swivel
519-5027	Spray Gun
519-5024	Spray Gun Repair Kit

Door & Weight Parts

<u>Part Number</u>	<u>Description</u>
103-2048	Door Cable – 8'
101-2023	Door Cable – 9' (Tall Units)
511-5252	Limit Switch
513-5702	1/8" Cable Clamp
105-6023	2 1/2" Cable Pulley



LVO Manufacturing, Inc.

808 N. 2nd Avenue E., P.O. Box 188

Rock Rapids, IA 51246

www.lvomfg.com

(712) 472-3734

1-800-346-5749

Fax (712) 472-2203

Electrical Parts

Part Number

Description

511-5257	Low Water Cut-Off Float
511-5272	On-Off Selector
511-5273	Wash Selector
511-5239	White LED Bulb
511-5214	Clear Indicator Light
511-5215	Amber Indicator Light
511-5216	Red Indicator Light
511-5270	Start Push Button
511-5269	Stop Push Button
511-5271	Auto Fill Push Button
511-5274	Clear Button Cover
511-5314	24 VAC Logic Controller
511-5338	Circuit Breaker, 4 Amp, 1 Pole
511-5340	Circuit Breaker, 5 Amp, 3 Pole
511-5342	Circuit Breaker, 15 Amp, 3 Pole
511-5344	Circuit Breaker, 25 Amp, 3 Pole
511-5345	Circuit Breaker, 30 Amp, 3 Pole
511-5348	Circuit Breaker, 63 Amp, 3 Pole
511-5294	Heater Contactor
511-5297	Pump Contactor – 208/230 Volt
511-5294	Pump Contactor – 460 Volt
511-5308	Pump Overload – 208/230 Volt
511-5305	Pump Overload – 460 Volt
511-5290	Fan Contactor
511-5300	Fan Overload
511-5056	0.250 KVA Control Circuit Transformer
511-5045	Fuse, 2 Amp, 500 Volt
511-5130	Fuse, 3 Amp, 250 Volt
511-5112	Fuse, 4 Amp, 250 Volt
511-5115	Fuse, 5 Amp, 500 Volt
511-5181	Fuse, 12 Amp, 250 Volt

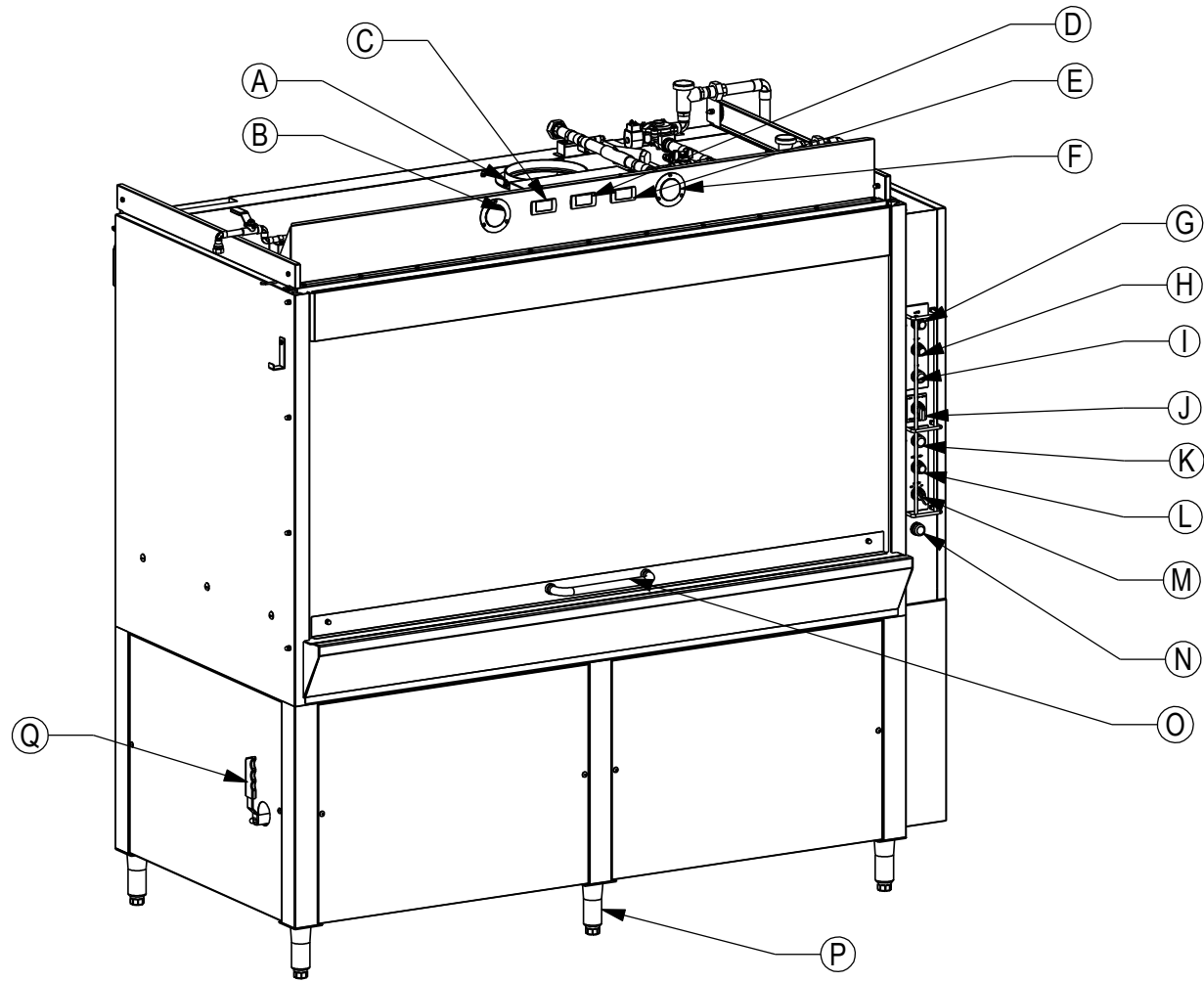

- | | | | | | |
|----|--------------------------------|----|---------------------|----|--------------------|
| A. | 8" STEAM VENT | G. | RINSE CYCLE LIGHT | M. | POWER SWITCH |
| B. | WASH PRESSURE GAUGE | H. | WASH CYCLE LIGHT | N. | AUTOFILL BUTTON |
| C. | WASH WATER TEMP GAUGE | I. | STOP BUTTON | O. | DOOR HANDLE |
| D. | RINSE TANK MANIFOLD TEMP GAUGE | J. | WASH CYCLE SELECTOR | P. | 6" STAINLESS LEG |
| E. | RINSE TANK TEMP GAUGE | K. | START BUTTON | Q. | 1 1/2" DRAIN VALVE |
| F. | RINSE PRESSURE GAUGE | L. | POWER LIGHT | | |



LVO Manufacturing, Inc
 808 N 2nd Ave E
 Rock Rapids, IA 561246
 Phone: (712) 472-3734

Mat. -	Scale 1:20	Name: Overview
Ga. - Finish -	5/25/2010	FL36
Rev. -	C. Woiwood	No. 106-1000-7

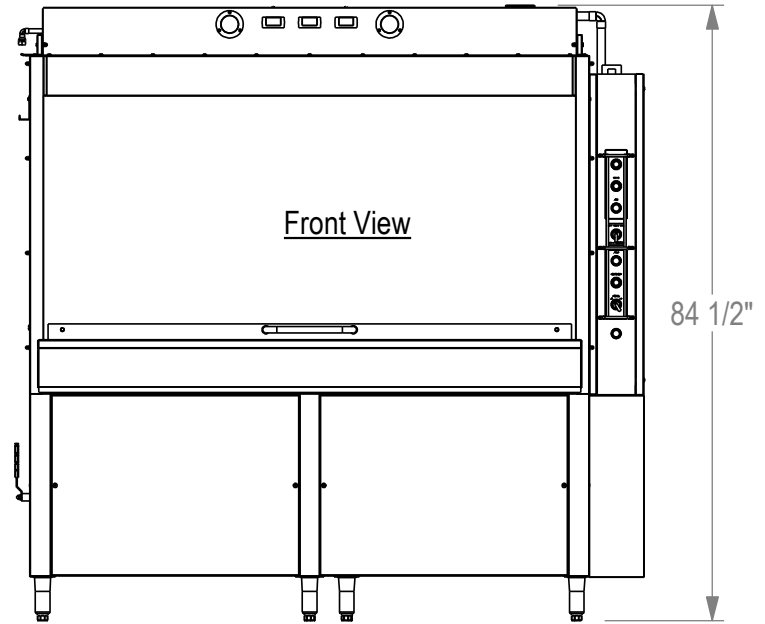
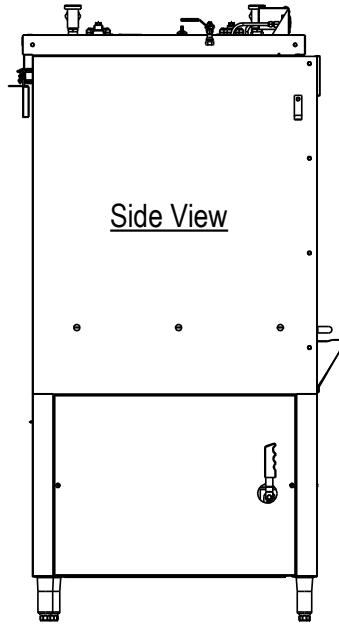
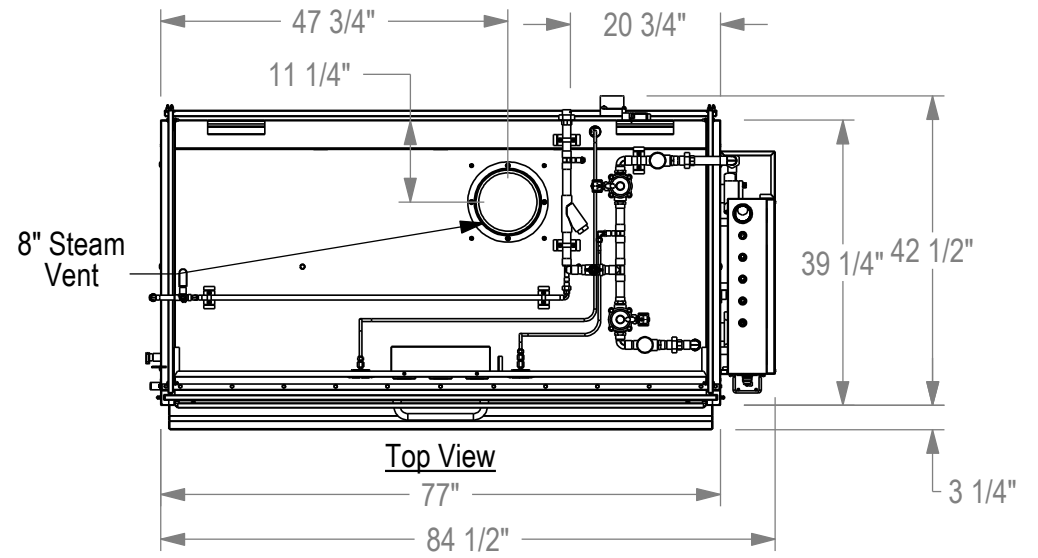
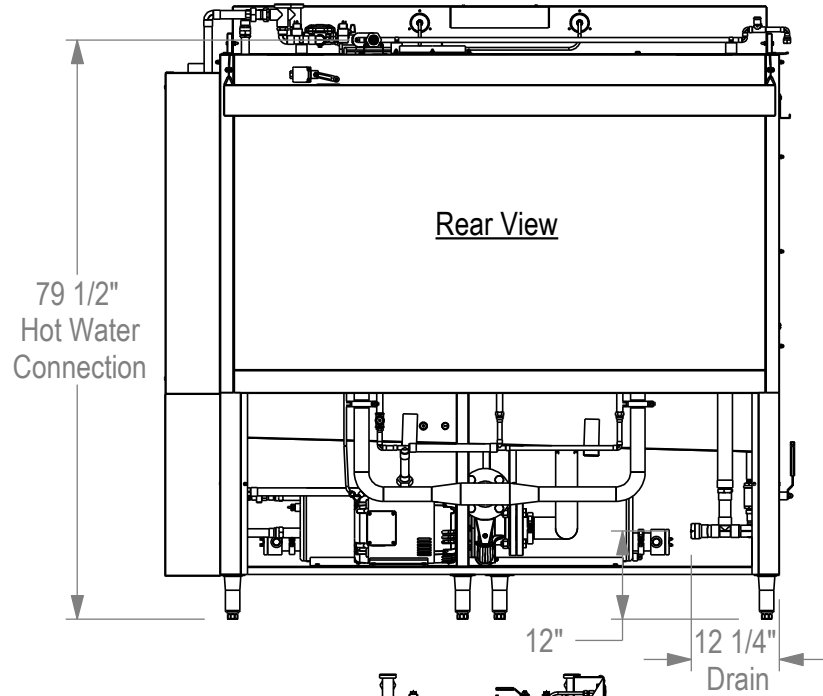

LVO Manufacturing, Inc
 808 N 2nd Ave E
 Rock Rapids, IA 561246
 Phone: (712) 472-3734

Mat. -	
Ga. -	Finish -
Rev. -	

Scale 1:26
5/26/2010
C. Woivood

Name: Informative
FL36 Electric
No. 106-1000-1

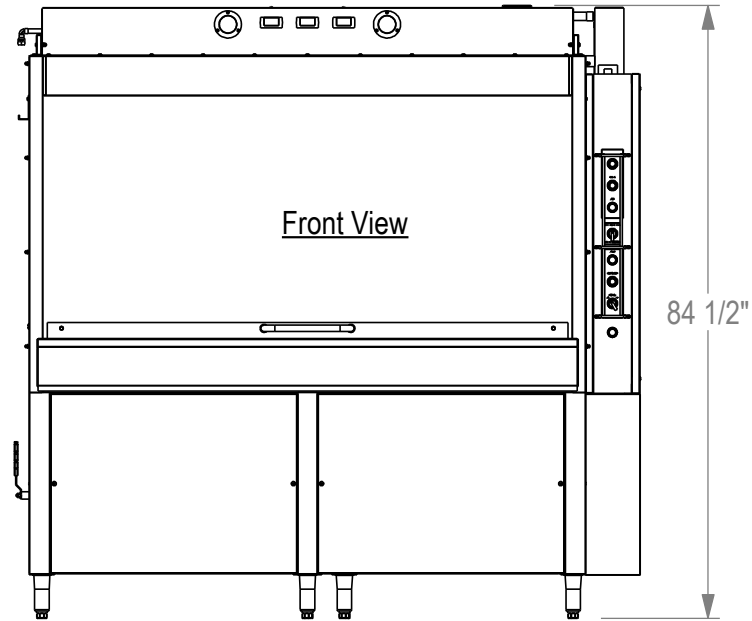
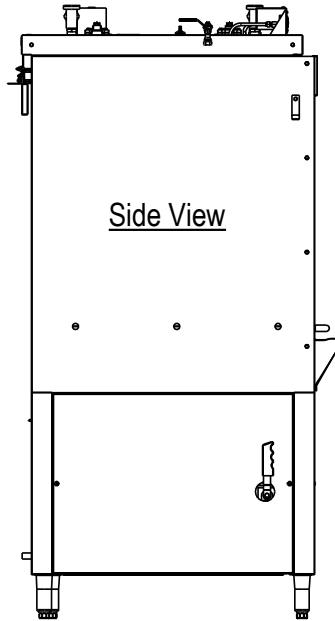
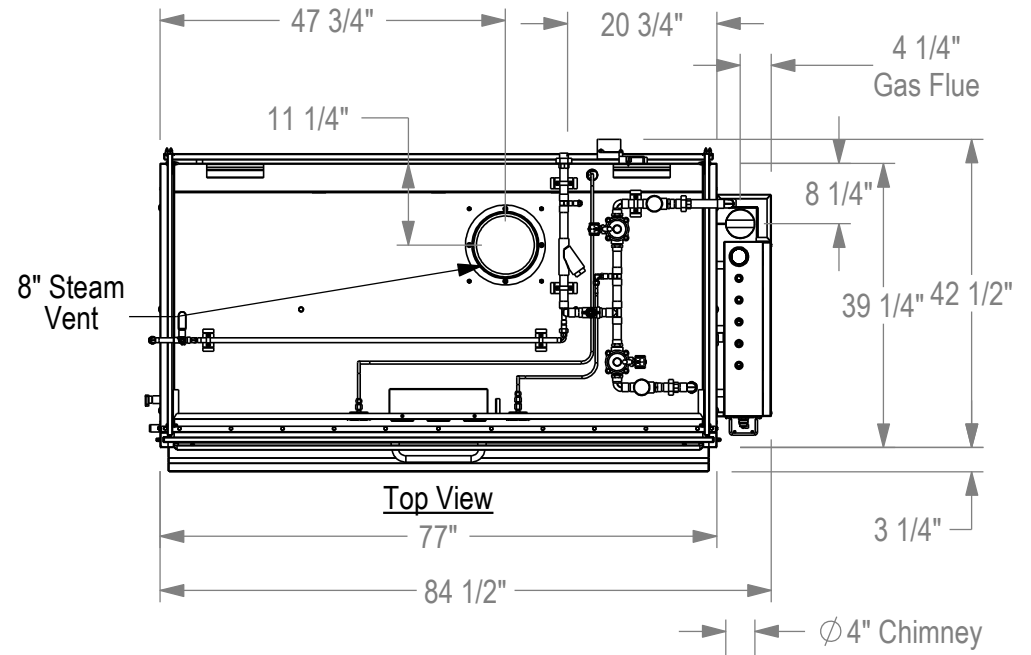
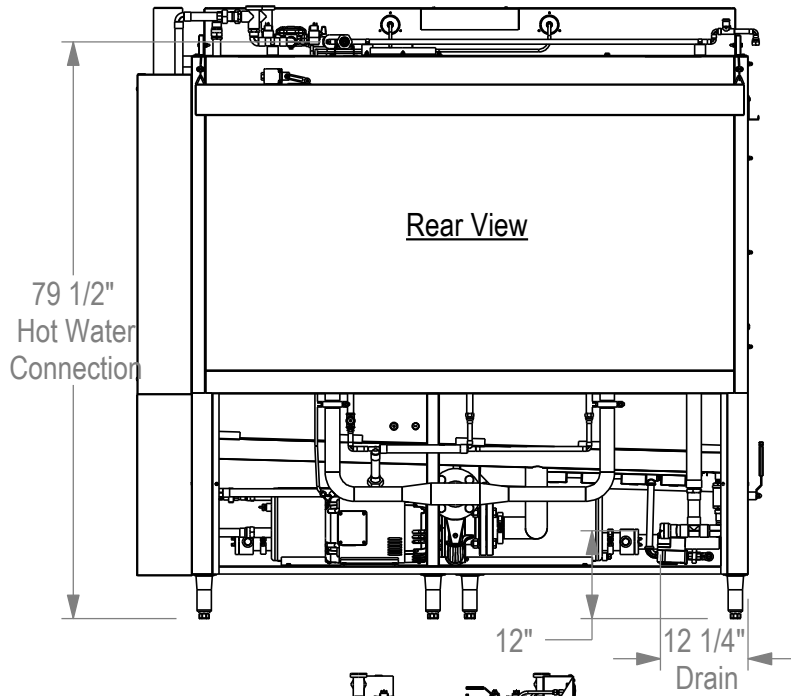

LVO Manufacturing, Inc
 808 N 2nd Ave E
 Rock Rapids, IA 561246
 Phone: (712) 472-3734

Mat. -	
Ga. -	Finish -
Rev. -	

Scale 1:26
5/26/2010
C. Woiwood

Name: Informative
FL36 Gas
No. 106-1100-1

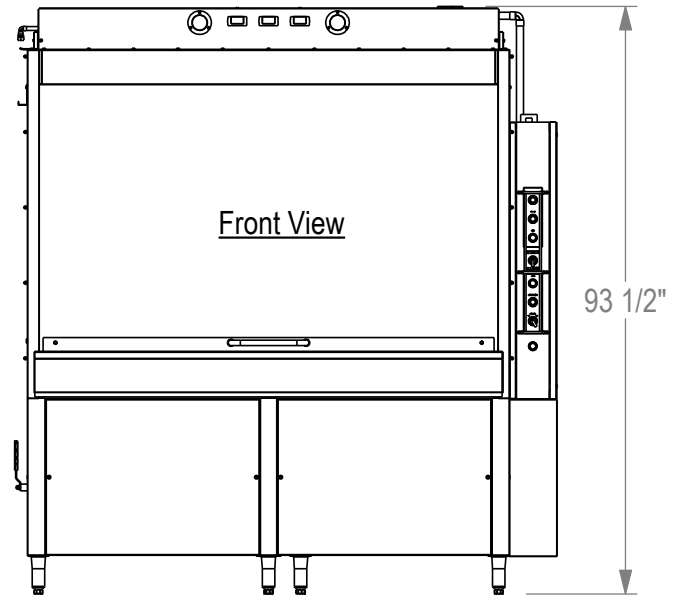
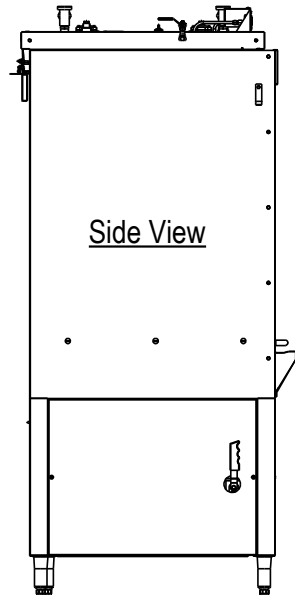
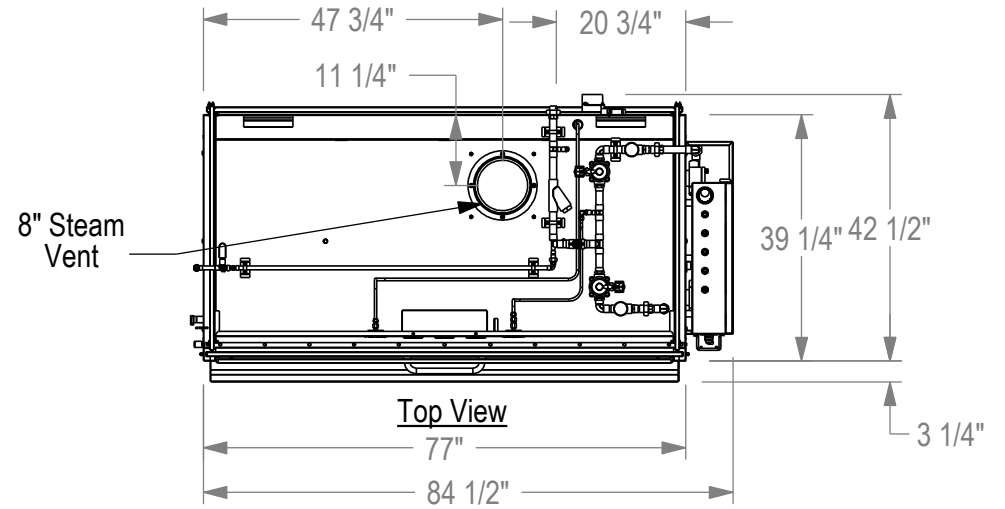
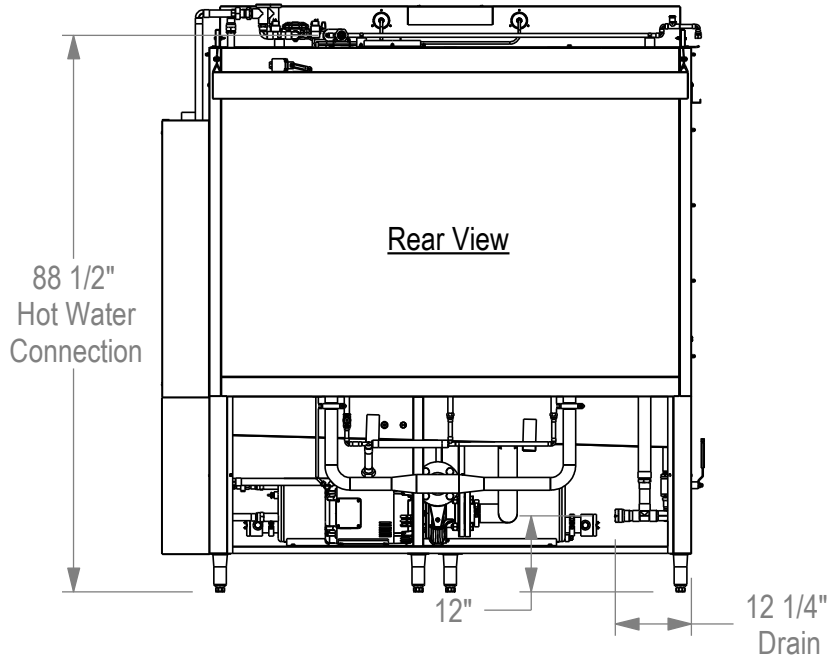

LVO Manufacturing, Inc
 808 N 2nd Ave E
 Rock Rapids, IA 561246
 Phone: (712) 472-3734

Name: FL36ET

5/26/2010

Scale 1:30

Ga. -

Finish -

Mat. -

C. Woiwood

Rev. -

No. 106-1400-1

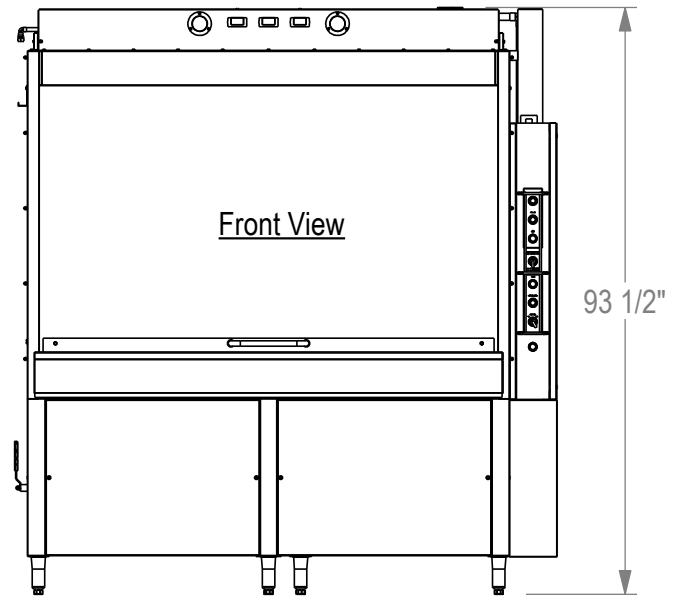
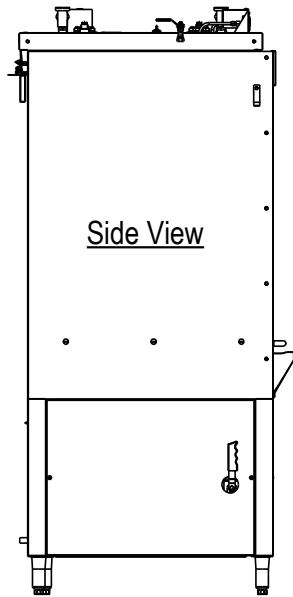
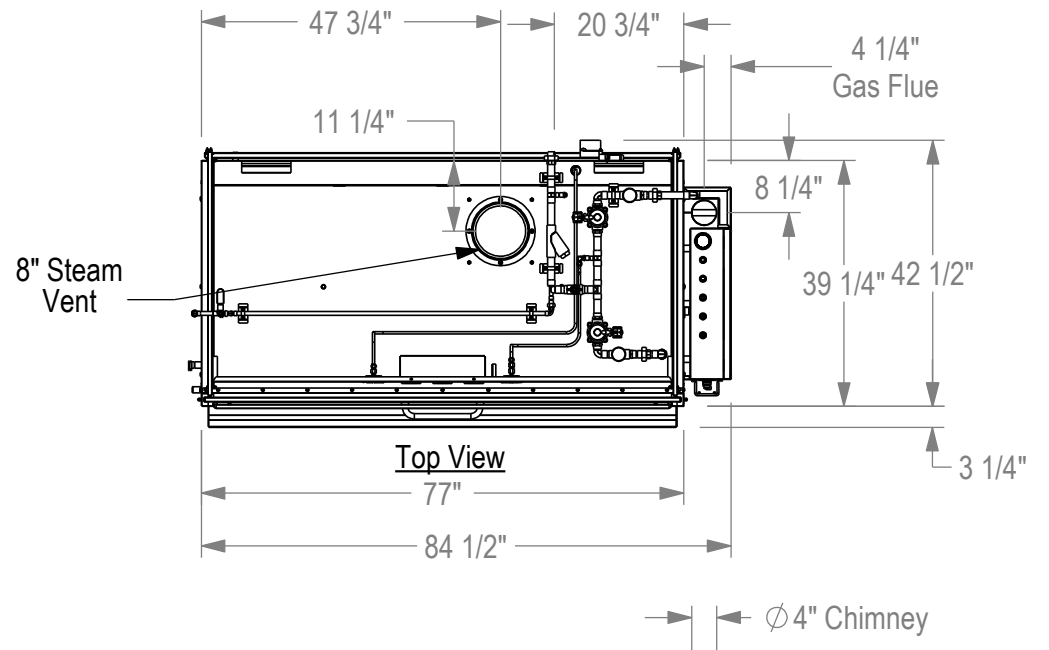
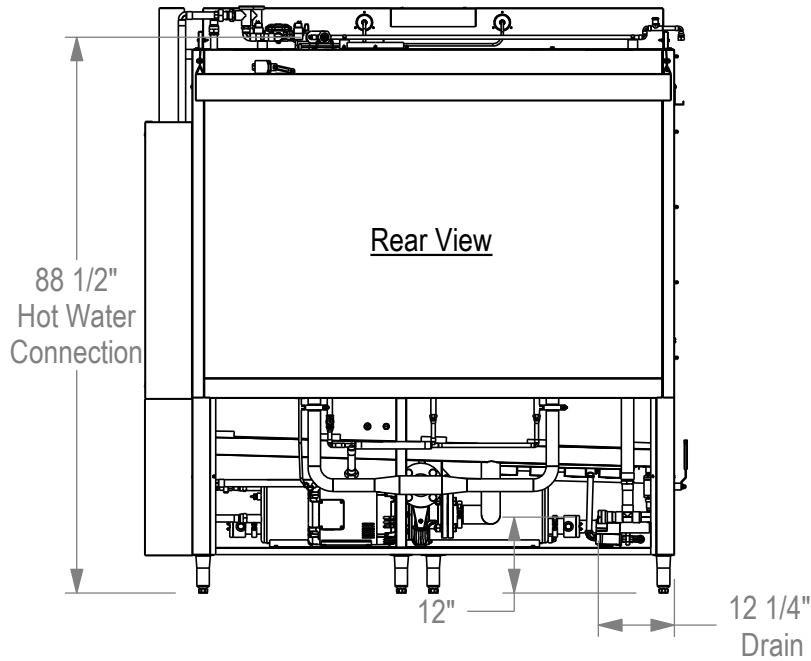

30



LVO Manufacturing, Inc
 808 N 2nd Ave E
 Rock Rapids, IA 561246
 Phone: (712) 472-3734

Mat. -	
Ga. -	Finish -
Rev. -	

Scale 1:30
5/26/2010
C. Woiwood

Name: Informative
FL36 Gas Tall
No. 106-1500-1

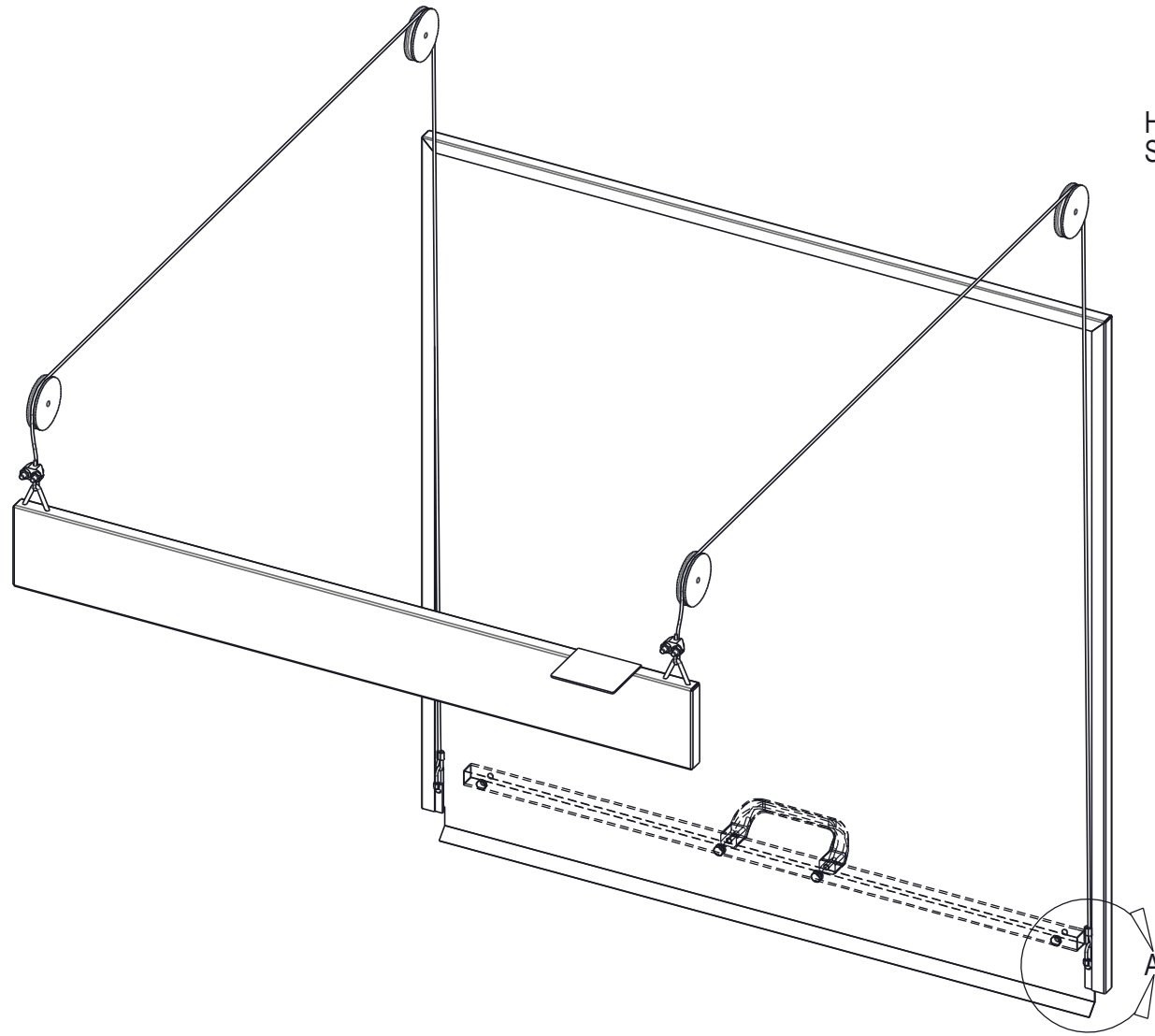

Hole May Need to be Drilled On Old Style Doors with Three Holes

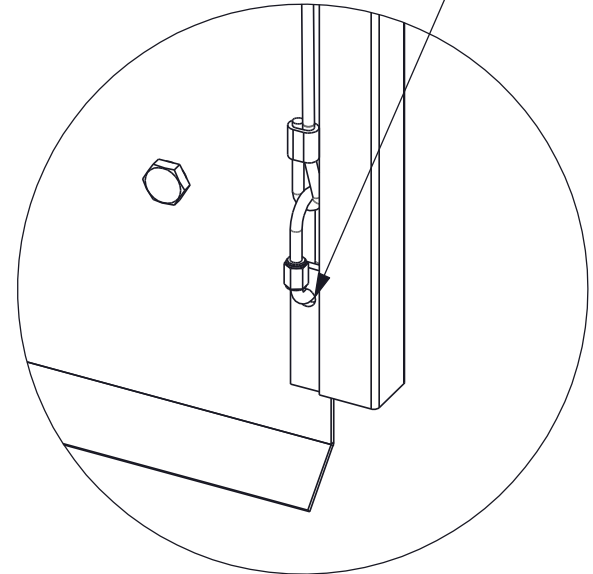

Detail A
Scale 1:2



LVO Manufacturing, Inc
808 N 2nd Ave E
Rock Rapids, IA 561246
Phone: (712) 472-3734

Mat. -	
Ga. -	Finish -
Rev. -	

Scale 1:8
4/21/2010
C. Woiwood

Name: Door & Weight Assembly
No. Door Weight

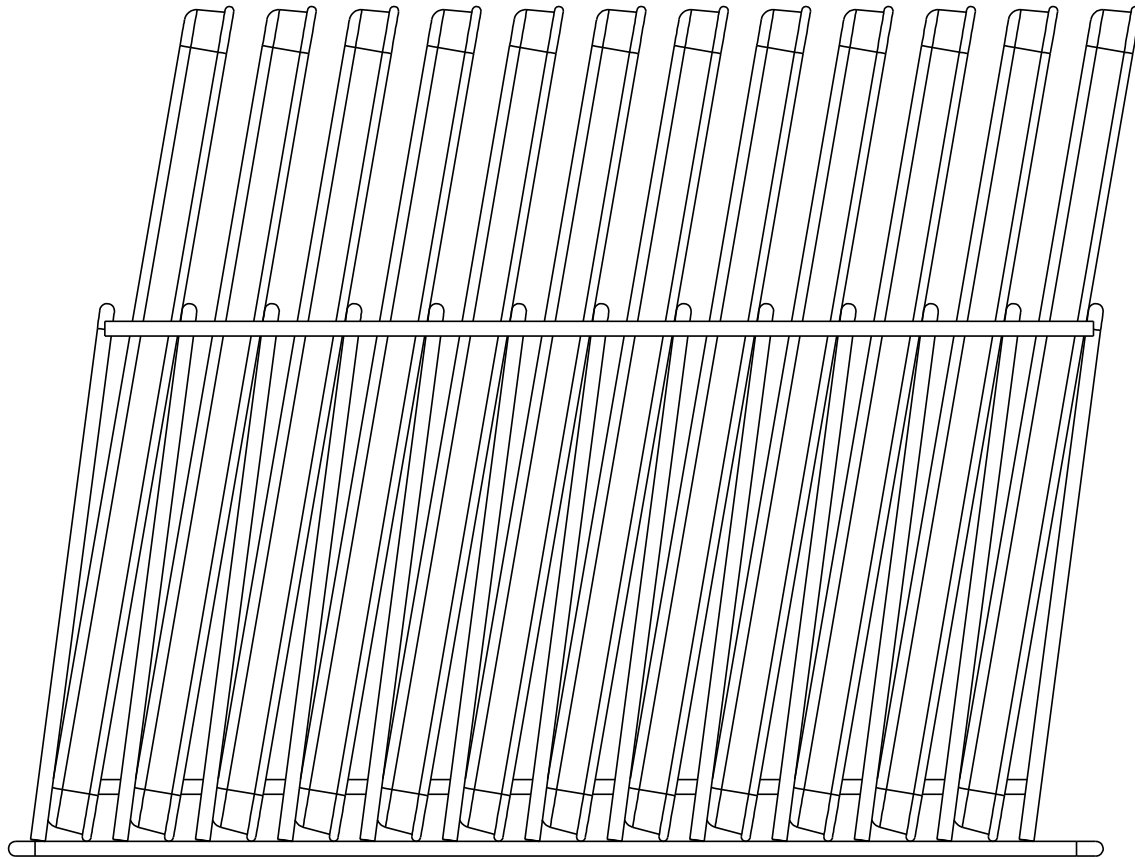

If necessary for extremely soiled pans, place pans in every other slot.



LVO Manufacturing, Inc
 808 N 2nd Ave E
 Rock Rapids, IA 561246
 Phone: (712) 472-3734

Mat. -	Scale 1:4	Name: Bun Pan Rack
Ga. -	Finish -	5/26/2010
Rev. -	<i>C. Woiwood</i>	No. 115-2011P
		Informative

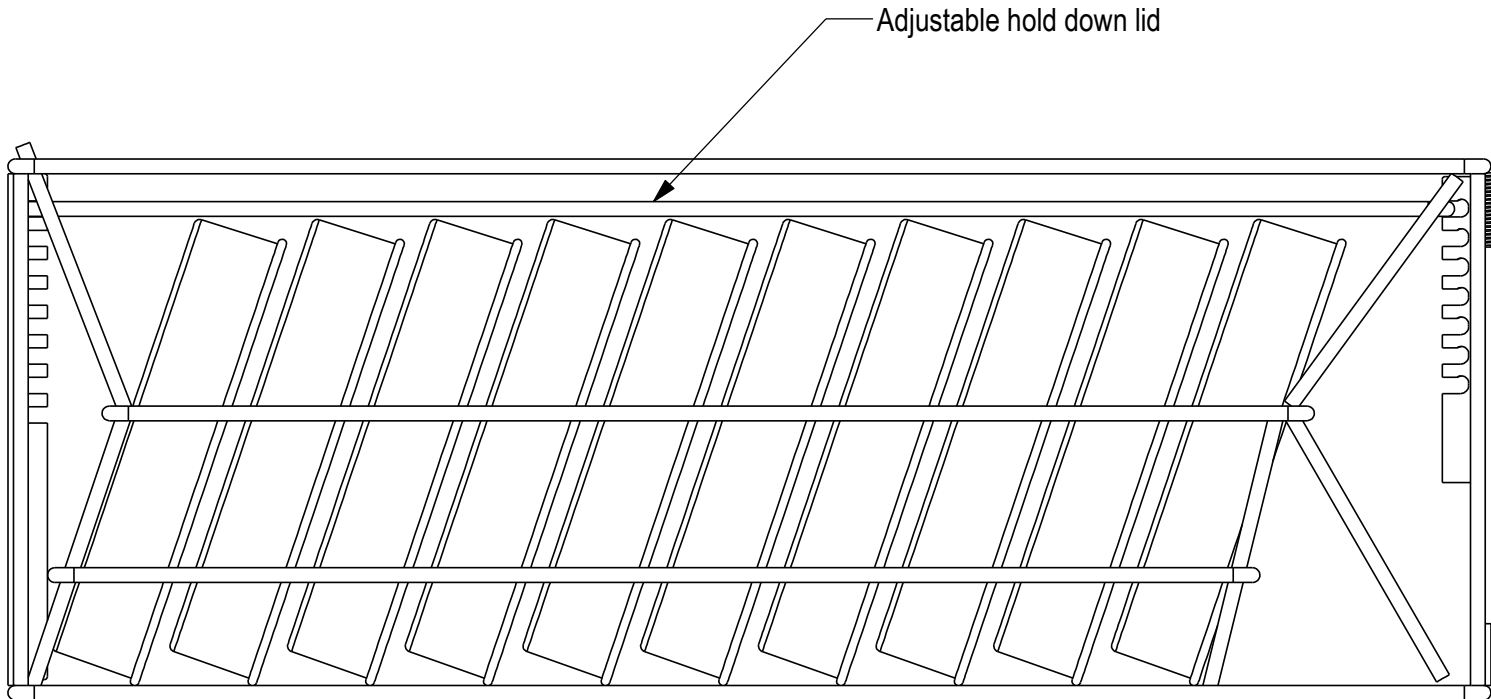

Insert pans as shown so bottom wash arms spray inside of pans.
 If necessary for extremely soiled pans, place pans in every other row.

	LVO Manufacturing, Inc 808 N 2nd Ave E Rock Rapids, IA 561246 Phone: (712) 472-3734		Mat. -	Scale 1:4	Name: Cake Pan Rack
	Ga. -	Finish -		5/26/2010	Informative
	Rev. -			C. Woiwood	No. 115-2101P

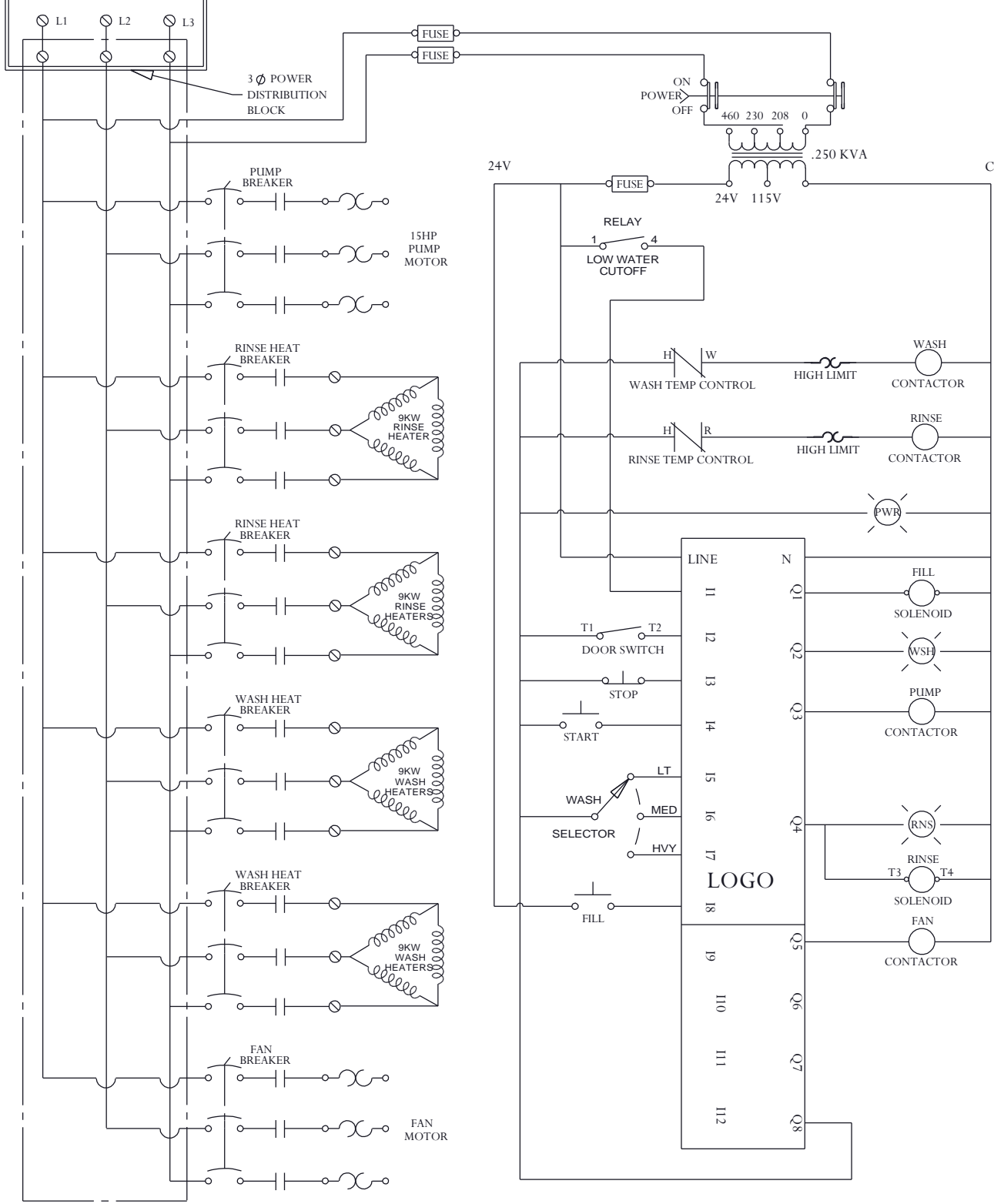

LVO Manufacturing, Inc.
808 N 2nd Ave E
Rock Rapids, IA 51246

Mat. -
Finish -
Rev. -
Phone: (712) 472-3734

Ga. -
Scale 1:1
08-21-2007
C. Woivood

Name: Ladder Diagram
FL36 Electric
No. 124L1125

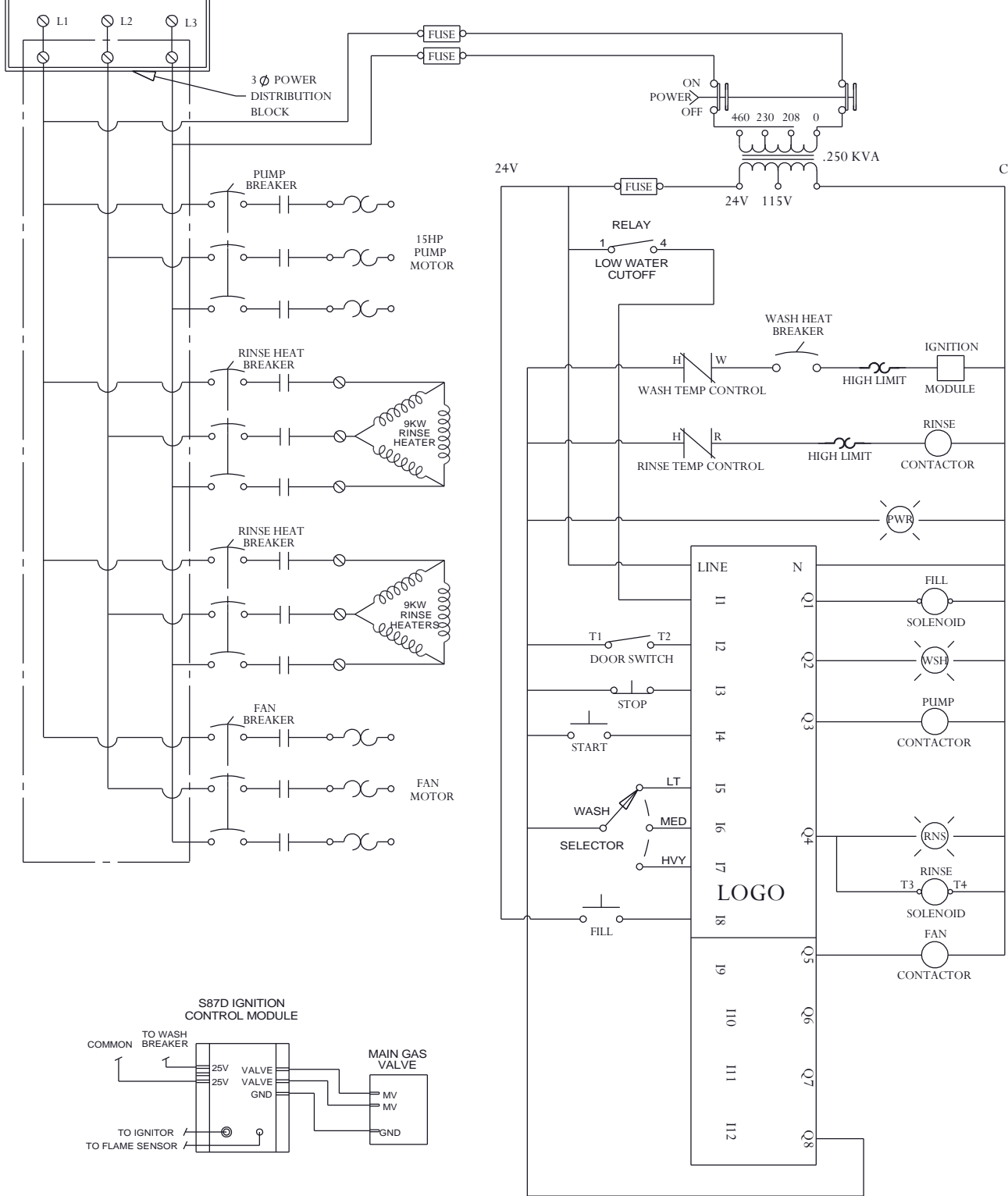

LVO Manufacturing, Inc.
808 N 2nd Ave E
Rock Rapids, IA 51246

Mat. -
Finish -
Rev. -
Phone: (712) 472-3734

Ga. -
Scale 1:1
08-21-2007
C. Woivood

Name: Ladder Diagram
FL36 Gas
No. 124L1128