



LVO Manufacturing, Inc.



RW1548 Pan-Washer
Owner's Manual





LVO Manufacturing, Inc.

808 N. 2nd Avenue E., P.O. Box 188

Rock Rapids, IA 51246

www.lvomfg.com

(712) 472-3734

1-800-346-5749 Fax (712) 472-2203

Warranty

LVO Manufacturing Inc. warrants equipment manufactured by it to be free from defects in material and workmanship for a period of one (1) year from date of delivery except as noted below.

LVO will **not** be held responsible for damage or unsatisfactory performance due to negligence, accident, alteration, unauthorized repair, improper installation or startup (see owner's manual), improper application, or improper maintenance (see owner's manual).

Parts found, on factory inspection, to be defective in workmanship or materials during the warranty period will be replaced (parts and labor, not overtime), provided the Buyer returns the defective parts to LVO Manufacturing Inc. within 30 days, transportation prepaid. LVO Manufacturing Inc. will pay UPS 2nd Day Air shipping charges for parts (with the exception of excessively large or heavy items) covered on warranty if the machine is not operational.

LVO Manufacturing Inc. reserves the right to make changes in design and construction of its products without imposing any obligation upon itself toward products previously manufactured.

This warranty is in lieu of any other warranties, expressed or implied, made on the part of LVO Manufacturing Inc. who does not accept responsibility to any purchaser of its products for any representation or warranty made by dealers or salespersons beyond those herein expressed including any implied warranties of merchantability or fitness for a particular purpose.

Warranty Procedure

- 1) Locate and record the 12 digit serial number located on the control box side of the rack washer.
- 2) Gather as much information about the problem as possible.
- 3) Call LVO Manufacturing Inc. at 1-800-346-5749 and request technical service. Prior to performing any warranty work, you must call the factory for a warranty authorization number (WA-____). This warranty authorization number must be on every invoice we receive for services rendered on the machine. Without this authorization number the invoice will not be paid. The warranty number must also be included with the defective part returned.**



LVO Manufacturing, Inc.

808 N. 2nd Avenue E., P.O. Box 188

Rock Rapids, IA 51246

www.lvomfg.com

(712) 472-3734

1-800-346-5749

Fax (712) 472-2203

Table of Contents

Warranty.....	2
Table of Contents	3
RW1548 Specifications.....	4
Electrical Data.....	5
Warnings & Cautions.....	6
Introduction.....	7
Installation Instructions.....	8
Startup Procedures	12
Sequence of Operation.....	14
Operation of Machine	15
Preventative Maintenance.....	18
Trouble Shooting – Electric Machines.....	19
Trouble Shooting – Gas Machines.....	20
Trouble Shooting – Steam Machines.....	20
Trouble Shooting Flowchart	21
Parts List	23
Drawings:	
(Drawing scales are approximate)	
General View	27
Four View – Electric	28
Four View – Gas	29
Concrete Pit Specifications	30
Pit Clearance Specifications.....	31
Stainless Steel Pit Liner	32
Bun Pan Rack.....	33
Cake Pan Rack	34
Bowl Rack.....	35
Ladder Diagram – Electric.....	36
Ladder Diagram – Gas	37



LVO Manufacturing, Inc.

808 N. 2nd Avenue E., P.O. Box 188

Rock Rapids, IA 51246

www.lvomfg.com

(712) 472-3734

1-800-346-5749

Fax (712) 472-2203

RW1548 Specifications

Overall Dimensions

Width – 59 ½”

Depth – 67 ½”

Height – 92 ½” (94 ½” gas units)

Height above floor – 81 ½” (Pit Models)

Wash Area – 31 ½” x 42” x 76 ½”

Hot Water System

1” hot water supply required, union provided

140°F water required at the machine

168 GPH at 20 PSI (14 gal/cycle x 12 cycle/hr)

Rinse booster: (2) 9 kW heating element in a 20 gallon rinse tank OR

½” steam coil in a 20 gallon rinse tank (Steam Only)

Full Load Amps

	208 Volt	230 Volt	460 Volt
Electric	142.1	128.6	65.4
Gas	92.1	83.4	42.8
Steam	42.1	38.2	20.2

Gas System (Gas Machines Only)

½” gas supply

Natural: 7” W.C. minimum inlet, 6” W.C. main manifold – 75,000 BTU

Propane: 11” W.C. minimum inlet, 10” W.C. main manifold – 60,000 BTU

4” dia. stainless steel chimney on back of machine (Draft diverter supplied)

Steam System (Steam Models Only)

¾” steam line, 10-15 PSI 76 lbs/hr average – Injected

76 lbs/hr average – Recirculating

Wash System

10 Hp & 5 Hp pumps in series recirculate approximately 240 GPM @ 55 PSI

Heat: Electric – (2) 9 kW heating elements

Gas – (3) 25,000 BTU rated infrared burners – 75,000 BTU total

Propane – (3) 20,000 BTU rated infrared burners – 60,000 BTU total

Injected & Recirculating Steam – 10 to 15 PSI, 37 lbs/hr average

65 gallon wash tank

1 ½” copper drain

8” steam exhaust vent companion flange

(Requires PVC, CPVC, or stainless steel field installed duct)



LVO Manufacturing, Inc.

808 N. 2nd Avenue E., P.O. Box 188

Rock Rapids, IA 51246

www.lvomfg.com

(712) 472-3734

1-800-346-5749

Fax (712) 472-2203

Electrical Data

Electrical Data for model RW1548 – Electric

	208 Volt	230 Volt	460 Volt
10 Hp Pump Motor	26.5	23.9	12.0
5 Hp Pump Motor	13.6	12.3	6.2
Control Circuit	2.0	2.0	2.0
Wash Heater (two 9 kW)	50.0	45.2	22.6
Rinse Heater (two 9 kW)	<u>50.0</u>	<u>45.2</u>	<u>22.6</u>
Total Running Current	142.1	128.6	65.4
Exhaust Fan (Opt.)	2.0	2.0	1.0

Electrical Data for model RW1548 – Gas

	208 Volt	230 Volt	460 Volt
10 Hp Pump Motor	26.5	23.9	12.0
5 Hp Pump Motor	13.6	12.3	6.2
Control Circuit	2.0	2.0	2.0
Rinse Heater (two 9 kW)	<u>50.0</u>	<u>45.2</u>	<u>22.6</u>
Total Running Current	92.1	83.4	42.8
Exhaust Fan (Opt.)	2.0	2.0	1.0

Electrical Data for model RW1548 – Injected or Recirculating Steam

	208 Volt	230 Volt	460 Volt
10 Hp Pump Motor	26.5	23.9	12.0
5 Hp Pump Motor	13.6	12.3	6.2
Control Circuit	<u>2.0</u>	<u>2.0</u>	<u>2.0</u>
Total Running Current	42.1	38.2	20.2
Exhaust Fan (Opt.)	2.0	2.0	1.0

*Electrical Supply to the machine should **exceed** the figures by the amount required by local codes.*

Note: Changing the voltage of the machine in the field requires different heating elements. Contact the factory if this situation arises.



LVO Manufacturing, Inc.

808 N. 2nd Avenue E., P.O. Box 188

Rock Rapids, IA 51246

www.lvomfg.com

(712) 472-3734

1-800-346-5749 Fax (712) 472-2203

Warnings & Cautions

General Warnings and Cautions:

1. Service work on the machine should be done by either a factory representative or qualified local service company. **Contact the factory if the machine is under warranty.**
2. Failure to follow the cleaning guidelines described in this manual will damage the machine and will void the warranty.

Gas Model Warnings and Cautions:

1. Installation must conform to local codes and the National Fuel Gas Code, ANSI Z223.1.
In Canada: Installation must be in accordance with CGA Standard CAN/CGA-B149.1, Natural Gas Installation Code or CAN/CGA-B149.2, Propane Installation Code.

FOR YOUR SAFETY: DO NOT STORE OR USE GASOLINE OR OTHER FLAMMABLE VAPORS OR LIQUIDS IN THE VICINITY OF THIS OR ANY OTHER APPLIANCE.



WARNING: IF YOU SMELL GAS, SHUT OFF THE GAS SUPPLY TO THE APPLIANCE, EXTINGUISH ANY OPEN FLAME, AND TEST ALL JOINTS WITH A SOAP SOLUTION. IF ODOR PERSISTS, CALL YOUR GAS SUPPLIER IMMEDIATELY.



AVERTISSEMENT: SI UNE ODEUR DE GAZ EST DÉCELÉE, COUPER L'ALIMENTATION EN GAZ DE L'APPAREIL, ÉTEINDRE TOUTES LES FLAMMES ET VÉRIFIER TOUS LES RACCORDS À L'AIDE D'UNE SOLUTION SAVONNEUSE. SI L'ODEUR PERSISTE, AVERTIR IMMÉDIATEMENT LE FOURNISSEUR DE GAZ.

2. Instructions should also be posted in a prominent location describing what to do in the event that the smell of gas is detected in the vicinity of the machine. (This information can be obtained from your local gas supplier).
3. Do not obstruct the flow of ventilation and combustion air to the machine.
4. Gas model rack washers are equipped with an electronic ignition that automatically lights the burners when the power switch is turned to the "ON" position and there is enough water in the machine. To shut the burners off, the power switch should be turned to the "OFF" position.



LVO Manufacturing, Inc.

808 N. 2nd Avenue E., P.O. Box 188

Rock Rapids, IA 51246

www.lvomfg.com

(712) 472-3734

1-800-346-5749

Fax (712) 472-2203

Introduction

This manual should be read and understood by everyone involved with the installation and operation of the rack washer. Keep this manual in a safe place for future reference. Extra copies or replacement copies can be purchased from the manufacturer.

Service work on the machine should be done by either a factory representative or qualified local service company. **Contact the factory if the machine is under warranty.**

The LVO rack washer is designed for use in bakeries, restaurants, schools, hospitals, and hotels, to clean pots, pans, bowls, and utensils. LVO rack washers are constructed of 14 gauge stainless steel (cabinets) and 12 gauge stainless steel (framework). The interior piping, rinse system, wash arms, and screens are stainless steel. Because of its sturdy construction, it will deliver years of powerful, thorough cleaning.

The machine is equipped with a heating element in the rinse tank to boost the rinse water to a sanitizing 180°F at the inlet to the machine. A rinse tank heated with recirculated steam is an option available on some models.

The wash tank on electric models incorporates two 9 kW electric heating elements for heating the wash water. The gas models use a series of (3) 25,000 BTU (20,000 BTU for propane) infrared burners. Steam models use either a direct injection system or a recirculated steam heating coil.

The pump recirculates wash water at approximately 55 pounds per square inch of pressure.

Each machine is equipped with two safety switches. The first is a low water cut-off, which shuts the machine off when the water level in the wash tank falls below the required level. The other safety device is a door switch, which prevents the machine from operating when the door is not completely closed. An electrical schematic for your machine is posted inside the control box cover.

Detergent Feeders

This machine must be operated with an automatic detergent feeder, which is supplied by the customer, including a visual means to verify that detergent is delivered or a visual or audible alarm to signal that detergent is not available for delivery. Power for the feeder can be provided by the pump supply connection in the control panel. See feeder equipment manual for additional information.



LVO Manufacturing, Inc.

808 N. 2nd Avenue E., P.O. Box 188

Rock Rapids, IA 51246

www.lvomfg.com

(712) 472-3734

1-800-346-5749 Fax (712) 472-2203

Installation Instructions

Step 1 READ: Read and understand these instructions thoroughly before attempting any part of the installation process.

 **WARNING: Not following these instructions may void warranty, cause damage to the equipment and/or cause injury to anyone involved in the installation or operation of this machine.**

A copy of the installation instructions and start-up procedure is printed on the sheet attached to the side of the machine. EVERYONE involved with the installation must be familiar with all aspects of the installation procedure.

Step 2 POSITIONING: The factory recommends leaving as much room as possible around the machine for future service work. No less than 16" should be allowed along the sides of the machine (36" for side with control box), and no less than 12" between the rear of the machine and the wall. Extra room around the machine will facilitate cleaning the washer area. Note: Gas models should be installed in a location free of drafts.

Step 3 UNCRATING: Leave the machine fully crated until the washer is placed in the location where it is to be installed. Inside you will find the accessories for the machine. Among these will be the fan and the legs (if ordered). The legs are adjustable by turning the small end one way or the other. Legs are only required for gas models on combustible floors.

When a pit is used, it can be installed prior to receiving the machine. There are two types of pit to choose from: concrete or stainless steel (see drawings). Concrete pits are the most common, and are usually installed by a general contractor. Note that the drain system will also need to be installed at this time. Generally, concrete pits are painted to make them waterproof.

A stainless steel pit is available for installations in buildings with basements. The stainless pit can also be used as a liner with concrete poured around it. The stainless steel pit is equipped with a coupler to allow the plumber to connect the drain (see drawings).

Prior to receiving the rack washer, the service lines can be stubbed in close to where the rack washer will be installed. This will speed up the completion of the installation once the machine is in place.

There are many methods for setting the machine in the pit. Often, the machine is slid into the pit from the front. Hydraulic jacks, pry bars, and pallet jacks or a forklift are usually necessary



LVO Manufacturing, Inc.

808 N. 2nd Avenue E., P.O. Box 188

Rock Rapids, IA 51246

www.lvomfg.com

(712) 472-3734

1-800-346-5749

Fax (712) 472-2203

to accomplish the task. Keep in mind that the heaviest part of the machine is the back where the pumps are located.

Once the machine is in the pit, the front floor grate(s) should be set in place. The machine should then be moved ahead to eliminate any gaps between the machine and grates, yet leaving enough space that the floor grate can be removed for periodic hosing down of the pit floor.

Step 4 DRAIN: Provisions for the drain should be made next. The rack washer has a copper drain located as shown on the drawings (see specifications page for drain size). The drain should be plumbed according to local code. Local ordinance may require a grease trap, vent, and/or a floor sink. If required, these should be installed before the machine is installed. It is strongly recommended that unions be used to allow the machine to be easily moved. Failure to do so may void the warranty.

Models that sit in a pit do not require a drain connection, as the wash tank drains directly into the pit.

Step 5 WATER SUPPLY HOOK-UP: The factory recommends 140°F hot water at the machine (see specifications page for water line size). This may require a dedicated water heater for the rack washer. If hard water is present, the manufacturer recommends installing a water softener or calcium filter. Hard water deposits will shorten the life of many of the components on the rack washer, resulting in higher maintenance costs. Please note that a union is installed at the point of hook-up (see drawings). This will allow the machine to be moved for service and cleaning. The customer must furnish a shut-off valve on the supply side of the union. This shut-off should be easily accessible to the operator of the machine. Additionally, if the machine is located a long distance from the water main, it may be necessary to supply a larger line to the machine to insure proper water pressure and flow for the machine to operate correctly.

Step 6 STEAM VENT: The machine is equipped with a collar for 8" duct work as shown on the drawings. This duct should be directly vented to the outside of the building. DO NOT vent into a wall, attic, or any other concealed space of the building, and avoid horizontal runs of duct.

The factory recommends 8" plastic pipe or stainless steel duct for the vent. If stainless steel is used, the duct work should be installed with reverse joints so that the condensate inside the vent can drain back into the machine without leaking, and all seams should be sealed with silicone sealant.

Generally, the machine ships with a 700 cfm, ½ Hp (¾ Hp on 50 Hz machines) squirrel cage fan.



LVO Manufacturing, Inc.

808 N. 2nd Avenue E., P.O. Box 188

Rock Rapids, IA 51246

www.lvomfg.com

(712) 472-3734

1-800-346-5749 Fax (712) 472-2203

The fan and included adapter should be mounted and sealed with silicone directly to the flange on the top of the machine before the ductwork is installed. The ductwork attaches directly to the side discharge of the fan. Wire and flex conduit are provided to wire the fan directly into the control panel. A dedicated circuit breaker and contactor for the fan are provided. The fan is controlled by a timer and runs for a short time at the end of the cycle, and when the door of the machine is open.

Note: Consult the factory before connecting any fan not supplied with the machine.

While the machine is designed to be directly connected to a vent, local or state codes may require a hood to be installed. Always check the local regulations prior to installing the vent.

Step 7 ELECTRICAL CONNECTIONS: The electrical connection to the machine should be made by a qualified electrician. All steps should be taken to insure that the supply voltage to the machine is the same as the rated voltage of the machine. Also, check that sufficient amperage is supplied to the machine (see specifications page for ratings).

A main power shut-off, supplied by the customer, must be installed near the machine in a place easily accessible by anyone operating or servicing the machine. The line from the main shut-off to the machine should be watertight flex conduit. The factory strongly recommends that a few extra feet be used to allow the machine to be moved if necessary. The wire used to supply the machine must be heavy enough to carry the amperage load of the machine.

The first connection should be the main ground to the grounding lug at the lower right hand corner of the control panel. Next, the hook-up can be made to the main power block.

Once the hook-up is complete, the circuit breakers in the control box of the washer must be checked to make sure they are in the “OFF” position. The main switch on the wall can then be turned on to power the machine.

Step 8 GAS CONNECTION (Gas Machines Only): A certified gas technician is required for the hook-up and final adjustments of the burners. This is necessary to insure proper inlet and manifold pressure for the gas machines (see spec page for gas pressure settings).

Verify the type of gas supply to be used, either natural or LP, and make sure the marking on the gas data plate agrees with that of the supply. The gas line hook-up must be made with a union at the location shown on the gas machine drawing (see spec page for gas line size). This line must have a shut-off valve (supplied by the customer) installed near the machine and accessible by anyone operating or servicing the machine.



LVO Manufacturing, Inc.

808 N. 2nd Avenue E., P.O. Box 188

Rock Rapids, IA 51246

www.lvomfg.com

(712) 472-3734

1-800-346-5749

Fax (712) 472-2203

A 4" stainless steel gas chimney runs up the back of the machine. A draft diverter is included with the machine (shipped inside the machine with the other accessories). The draft diverter must be installed on top of the factory installed chimney. The Type B gas flue can then be continued to the outside of the building per local codes.

The initial start-up of the burners should not be done until the start-up procedures for the machine on the following pages have been completed.

Step 9 STEAM CONNECTION (Steam Machines Only): A steam line is required to supply the steam injector or recirculated steam heat exchanger coil (see spec page for size of steam line). A strainer is already built into the machine but a union will be required in the supply line (supplied by the customer). The specification sheet above lists the rated pressure and average steam consumption rate for the machine.



LVO Manufacturing, Inc.

808 N. 2nd Avenue E., P.O. Box 188

Rock Rapids, IA 51246

www.lvomfg.com

(712) 472-3734

1-800-346-5749 Fax (712) 472-2203

Startup Procedures

 **Warning:** These instructions must be followed or damage to the machine will result.

Step 1: Close drain valve. See drawings for location. On machines equipped with and **Auto Drain** option, the drain valve will automatically close when the **Auto Fill** button is pushed.

Step 2: With the circuit breakers in the control panel of the machine in the “OFF” position and the main power supply to the machine connected, the **ON-OFF switch** on the button panel can be turned to the “ON” position. Then wait approximately 5 seconds for the machine controller to power up.

Note: The amber power light will not turn on until there is sufficient water in the machine.

Step 3: Fill the machine by pressing the **Auto Fill** button. The machine will continue to fill for 90 seconds past the point where the low water protection device is energized, turning on the power light and temperature controllers. **The machine is equipped with a low water protection device and will not run without sufficient water in the wash tank.**

Note: The machine has a door switch and will not operate with the door partially open.

Step 4: With the machine full of water and with the door closed, press the start button and let the machine go through a complete cycle. The timers in the control panel will go through their sequence, lighting the wash and rinse lights on the front of the machine. The cycle is complete when the red light goes off and the amber light stays on. The pump will not run at this time because the pump circuit breaker in the control panel is in the “OFF” position.

Step 5: Repeat **Step 4** at least two times or until water can be heard spraying out of the rinse nozzles. This ensures that the rinse tank is full of water before the heating element is energized.

Step 6: All circuit breakers in the control panel can now be switched to the “ON” position. This will energize the heating system in the wash and rinse tanks.

Step 7: Check the pumps for proper rotation by pressing the start button and observing the wash pressure gauge on the front of the machine for 5 to 10 seconds. Then press the stop button. The wash pressure should be 45-60 psi. If the pressure is erratic and only rises to about 20 psi, the pumps are running backwards. The pumps will also have a noticeable growl when running backwards. Disconnect power to the machine and reverse the outside two wires that feed the power block in the control panel. Reconnect power and run the pumps again to confirm that it is operating correctly.



LVO Manufacturing, Inc.

808 N. 2nd Avenue E., P.O. Box 188

Rock Rapids, IA 51246

www.lvomfg.com

(712) 472-3734

1-800-346-5749

Fax (712) 472-2203

Step 8: With the power on, the wash and rinse heating systems should be checked. The rinse tank should take 5 to 10 minutes to reach 200°F and the wash should take approximately 60 minutes to reach 160°F. The times will vary depending on the temperature of the incoming water. **Note:** The rinse manifold gauge measures the temperature of the rinse water just before it enters the machine. Therefore, this temperature reading is only accurate while the machine is rinsing.

If the machine is not reaching temperature, check to make sure that all the breakers in the control panel are in the “ON” position. If the wash tank is gas heated, make certain the main gas valve is open. During initial start-up, gas machines may have to be turned on and off several times to bleed the air out of the gas lines. Wait about a minute after turning the machine off before turning it back on. If the machine still does not appear to be heating up properly, call LVO Manufacturing at 1-800-346-5749.

Step 9: Set the rinse pressure by changing the pressure adjustment valve located on the back of the machine. The pressure should be set at 20 psi on the rinse gauge **while the machine is rinsing.** Variations in building water pressure may require the pressure to be increased or decreased from its factory setting.

Step 10: Machines are equipped with an **Auto Fill** and have a timer in the electrical panel that controls the fill valve. Adjust the timer so that the machine fills to the overflow tube (or until water just begins to run out of the machine’s drain) when the **Auto Fill** button is pressed.

Step 11: If the machine is equipped with the fan option, (see Step 6 in the Installation Instructions for a description of the fan option) verify that it is rotating in the correct direction. If the fan is blowing into the machine rather than out the vent, switch the two outside wires on the three phase connection in the control panel. Recheck to confirm proper rotation.

Step 12: Replace all covers and peel off the plastic protective coating, tape, etc. from the machine that may have been used to prepare the machine for shipping.



LVO Manufacturing, Inc.

808 N. 2nd Avenue E., P.O. Box 188

Rock Rapids, IA 51246

www.lvomfg.com

(712) 472-3734

1-800-346-5749

Fax (712) 472-2203

Sequence of Operation

- Power switch is switched “ON”
- Control panel logic control is energized
- Fill button energizes the fill solenoid
- Low water safety switch closes terminals 1 and 4 in the control panel if there is sufficient water in the wash tank
- Amber indicator light comes on
- Wash and rinse temp controls are energized
- Temp controls energize wash and rinse heating systems
- Door safety switch is energized
- Stop and Start buttons are energized
- Start button is pushed energizing the internal timing functions of the logic control
- Red indicator light is energized
- Wash timer (Light, Medium, or Heavy) starts, energizing the pump contactor for set amount of time
- Wash time runs out energizing the rest timer
- After set amount of rest time, the rinse timer starts, energizing the rinse solenoid valve and clear indicator light
- If the machine is equipped with the exhaust fan option, the fan timer runs for the set time when the rinse cycle is completed
- After the rinse timer (or optional fan timer) has timed out, all timers are reset, and the red indicator light is de-energized



LVO Manufacturing, Inc.

808 N. 2nd Avenue E., P.O. Box 188

Rock Rapids, IA 51246

www.lvomfg.com

(712) 472-3734

1-800-346-5749

Fax (712) 472-2203

Operation of Machine

Initial Daily Startup

1. Check if the inside of the machine has been properly cleaned since its last use. If not, clean the machine (refer to **Final Clean-Up** on the following page for cleaning information).
2. Make sure scrap tray screens and the pump inlet screens are in place.
WARNING: Do not operate washer without all screens in place.
3. Close the drain valve.
4. Turn power switch to “ON” position, allow approximately 5 seconds for the internal logic controller to power up, and push the **Auto Fill** button to fill the unit.
5. Allow wash and rinse temperatures to come up to recommended levels.
6. While machine is warming up, the first load can be prepared and placed in the machine. If the pans are excessively dirty, they should be pre-soaked and scraped before being placed in the rack. Pan preparation will reduce the need to change the wash water and will speed-up the entire washing process. The correct manner for loading the racks is illustrated on the drawings later in this manual.
7. Once the machine has reached the recommended temperatures, detergent should be added to the wash water. Detergent should be used according to the recommendations of the chemical supplier. A non-suds detergent is necessary and local water conditions should be considered when selecting the concentration of the detergent. An automatic soap dispenser should be installed at the job site by the chemical supplier. There should be a visible or audible means of determining detergent delivery. If they have any questions concerning the installation of their dispenser to the LVO rack washer, they can call the factory for advice (800-346-5749).
8. The rack of pans can now be placed in the machine. The rack should be centered in the machine to subject the pans to the full force of the spray arms.

WARNING: Loose items and glassware should not be put in the washer. The high pressure wash cycle will damage them and potentially the machine.

Bowls or buckets can be washed by placing them in the bowl/utensil rack with the tops toward the lower side of the shelf to facilitate draining.

The utensil basket is to be used to contain smaller items such as paddles, whisks, scrapers, etc.

CAUTION: When loading the machine make sure that nothing will obstruct the path of the wash arms. This will avoid damage to the machine and to the items being washed.



LVO Manufacturing, Inc.

808 N. 2nd Avenue E., P.O. Box 188

Rock Rapids, IA 51246

www.lvomfg.com

(712) 472-3734

1-800-346-5749 Fax (712) 472-2203

When loading bowls, pans, or buckets into the machine make sure they are loaded in a manner that will allow the wash water to drain out of them.

9. The machine cycle is completely automatic with adjustable wash, rest, and rinse timers. The timers are located in the control panel and are factory set to the following recommended values:

Wash: Light	3 Min
Medium	5 Min
Heavy	7 Min
Rest:	20 Sec
Rinse:	60 Sec
Fan (Optional)	30 Sec

Select length of wash (Light/Medium/High) with the 3 position selector on the button panel and push the green start button to initiate the wash cycle. The red indicator light will come on. At the end of the wash cycle, the red light will stay on and the 20 sec rest will begin. The rest period allows the wash water and suds to drain from the pans. After the rest cycle, the rinse cycle begins. During the rinse cycle, the clear indicator light will come on. If the machine is equipped with a fan timer (see above for a description of the fan), the fan will start after the rinse is finished. After the rinse or fan cycle is finished, the red light will go off. The cycle is now complete. The amber power light will stay on as long as the power switch is in the "ON" position and there is enough water in the machine.

10. Throughout the day as the machine is being used, the scrap tray screens should be periodically removed from the machine, dumped out, washed out in the sink and replaced in the machine.

Final Cleanup

At the end of each day's use, the operator of the machine must clean the machine according to the following procedure:

1. Check and clean any plugged wash nozzles. Use a piece of wire to push any obstruction out of the nozzle into the wash arm. When all of the nozzles have been cleared, close the door; push the start button running the machine for a few seconds to blow the debris out of the wash arms. Push the red "STOP" button. If necessary, the wash arm assembly can be removed by pulling out the grip ring pin and sliding the assembly out of the hub.
2. Turn the machine off and open the drain valve. For machines equipped with the Auto Drain option, press Drain Button.
3. Remove the scrap trays, dump them out, and wash them off in the sink.



LVO Manufacturing, Inc.

808 N. 2nd Avenue E., P.O. Box 188

Rock Rapids, IA 51246

www.lvomfg.com

(712) 472-3734

1-800-346-5749

Fax (712) 472-2203

4. Spray down the inside of the machine.
5. Brush off the heating element (electric models) and anywhere that doesn't come clean from spraying with the hose.
Note: On electric models, brushing the element is very important in prolonging the life of the element.
6. Check and clean the rinse nozzles.
7. Spray down the inside of the machine again.
8. Remove the pump inlet screen and clean it thoroughly in the sink.
Note: While removing the screen be careful not to allow any debris to fall into the pump inlet opening.
9. Replace the pump inlet screen, scrap tray screens, and floor grates.
10. Close the drain and leave the machine empty of water until it is to be used again.
11. (For pit models only) Remove the front floor grate(s) and spray pit floor from front toward the rear. Clean the pit drain thoroughly. Water backup from a clogged drain will cause major burner damage! DO NOT allow overspray on the burner when cleaning. Burner firing problems will result. When cleaning is complete, replace the floor grate(s).



LVO Manufacturing, Inc.

808 N. 2nd Avenue E., P.O. Box 188

Rock Rapids, IA 51246

www.lvomfg.com

(712) 472-3734

1-800-346-5749 Fax (712) 472-2203

Preventative Maintenance

- Turn off power and drain machine, making sure it drains freely.
- Check machine for general cleanliness. Make sure the pump screen and scrap trays are clean and properly in place. Wash heating elements (electric models only) must be cleaned on a daily basis for proper operation. Check for plugged wash and rinse nozzles. If necessary, the entire wash arm assembly can be removed by pulling out the grip ring pin and sliding the assembly out of the hub. These items are part of the daily maintenance schedule.
- Check for excessive play in the hub/wash arm assemblies. Excessive wear can affect the wash pressure and shorten the life of some hub components. Hub repair kits are available from the factory.
- Close drain valve and fill machine, making sure drain does not leak (some water may initially run out of the drain through the overflow). Run through a Light, Medium, and Heavy wash cycle, checking for proper timer operation.
- Check if Power, Wash, and Rinse lights are working.
- Check if pump pressure during wash cycle is within recommended range (45-60 psi).
- Check if rinse pressure is approximately 20 psi. Note: This must be checked during rinse cycle for accurate reading.
- Make sure steam exhaust fan is working properly. See **Step 6** in the Installation Instructions for proper operation.
- Allow machine to heat up to recommended temperatures, making sure the temperature controls are operating properly. Wash temperature and Rinse Tank temperature should be noted at this time. The rinse water temperature gauge is accurate only during rinse cycle and should be checked while machine is rinsing.
Note: If a qualified technician is available, current readings for heating elements should be taken to ensure they are heating properly.
- Machines with slide-up doors, door cables and connections should be inspected for damage or excessive wear and replaced if necessary. Make sure cable pulleys turn freely and door switch is still adjusted properly.
- Pump motor(s) should be greased occasionally depending on usage. Once or twice yearly should be sufficient under normal use.

Note:

Items above marked ● are easily identified visually and should be checked on a daily basis. Other items should be checked periodically, depending on usage.

Time required for complete inspection may vary, depending on wash timer settings, heat up time, etc. One to two hours is a reasonable amount of time unless problems are encountered that need attention. If any problems or questions arise, call the factory for assistance.



LVO Manufacturing, Inc.

808 N. 2nd Avenue E., P.O. Box 188

Rock Rapids, IA 51246

www.lvomfg.com

(712) 472-3734

1-800-346-5749

Fax (712) 472-2203

Trouble Shooting – Electric Machines

<u>Problem</u>	<u>Cause</u>	<u>Cure</u>
Machine won't run	No power to machine Not enough water Door open	Check building power supply Fill machine until overflowing Close door tightly
Wash pressure too high	Nozzles plugged	Remove debris from nozzles
Wash pressure too low	Pump running backwards Pump screen clogged Excessive suds Missing wash nozzles Upper pump not starting	See Installation Instructions See Cleaning Instructions Change soap or use less Replace nozzles or wash arm Check pressure switch
Wash temperature too low	Thermostat set too low Wash element blown	Adjust wash thermostat* Replace wash heating element
Rinse temperature too low	Thermostat set too low Water supply too cold Rinse element blown	Adjust rinse thermostat* Set building hot water at 140°F Replace rinse heating element
No rinse water	Nozzles plugged Solenoid valve stuck Rinse strainer clogged	See Cleaning Instructions Clean or replace solenoid valve Clean pressure regulator/strainer
Rinse does not shut off	Rinse solenoid stuck open	Clean or replace solenoid valve
Utensils not clean	Wash time too short Water too hard Wash temperature too low Detergent problem Improper stacking of utensils	Use longer wash Install softener Adjust thermostat* Consult chemical supplier See racking instructions

* **WARNING:** Do not set rinse thermostat above the boiling point of water. The boiling point of water decreases with increased elevation at approximately 2°F per 1000 ft of elevation.



LVO Manufacturing, Inc.

808 N. 2nd Avenue E., P.O. Box 188

Rock Rapids, IA 51246

www.lvomfg.com

(712) 472-3734

1-800-346-5749 Fax (712) 472-2203

Trouble Shooting – Gas Machines

(Same as electric model except for the following)

Low wash temperature:

1. Check temperature control set point.
2. Check switches, fuses, and breakers that control the burners.
3. Check to be sure electrical power and gas supply have not been interrupted to the burners.
4. Check that all shut-off valves in the gas line and main gas valve are in the “OPEN” position.
5. Reset ignition control & try again. To reset control:
 - a. Turn On-Off switch to “Off” position.
 - b. Wait one minute, turn switch to “On” position.
6. If above steps do not light the main burner, call your local gas appliance service technician. Provide the person working on the machine with the ignition system information included with this owner’s manual.



WARNING: DO NOT ATTEMPT TO LIGHT BURNER MANUALLY

Trouble Shooting – Steam Machines

(Same as electric model except for the following)

Low wash temperature:

1. Check temperature control set point.
2. Check boiler pressure.
3. Check to be sure electric signal is being sent to the steam solenoid.
4. Verify that the strainer in the steam line is open.
5. Check steam solenoid.

WARNING: Do not set rinse thermostat above the boiling point of water. The boiling point of water decreases with increased elevation at approximately 2°F per 1000 ft of elevation.



LVO Manufacturing, Inc.

808 N. 2nd Avenue E., P.O. Box 188

Rock Rapids, IA 51246

www.lvomfg.com

(712) 472-3734

1-800-346-5749

Fax (712) 472-2203

Trouble Shooting Flowchart

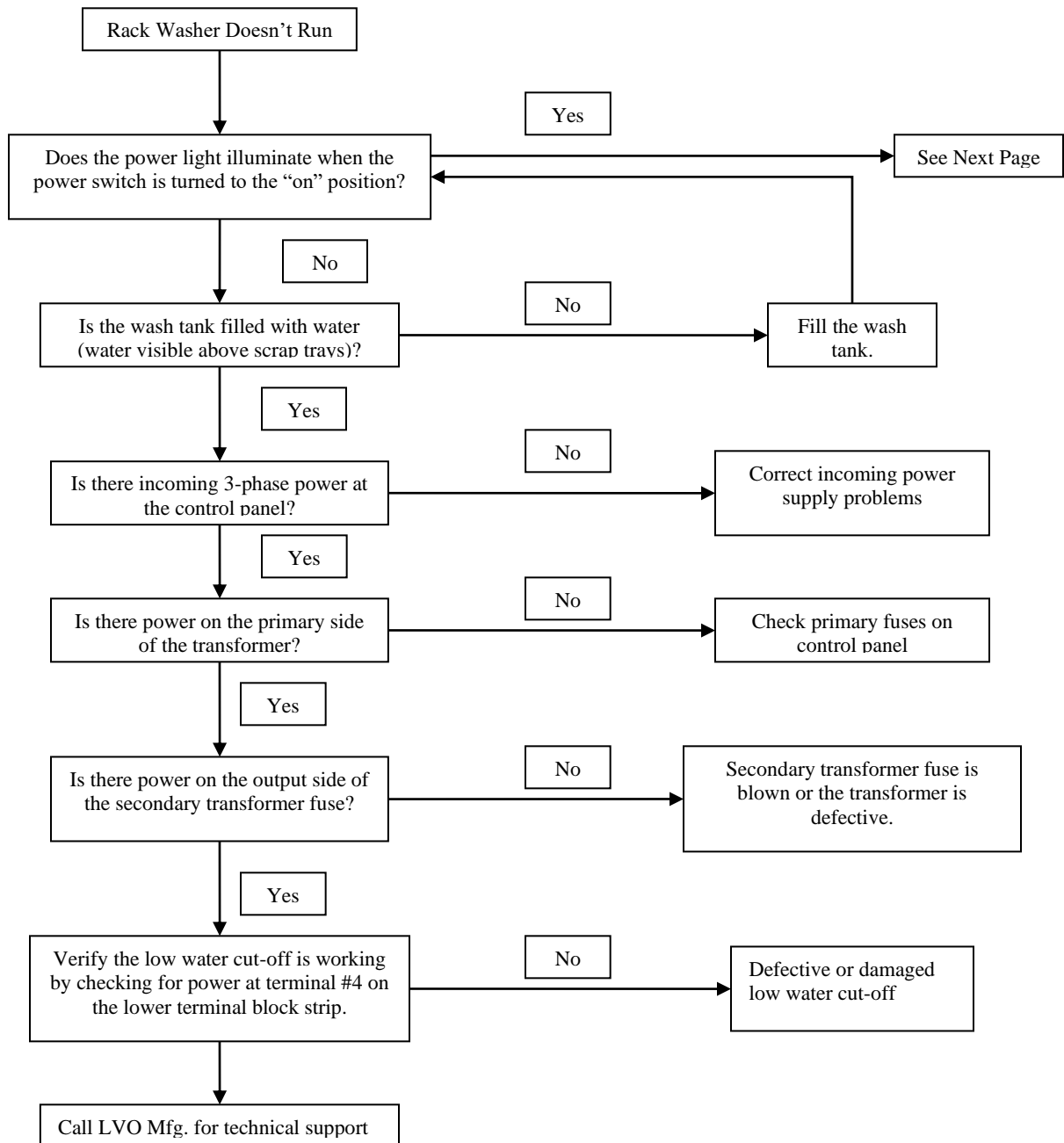



LVO Manufacturing, Inc.

808 N. 2nd Avenue E., P.O. Box 188

Rock Rapids, IA 51246

www.lvomfg.com

(712) 472-3734

1-800-346-5749 Fax (712) 472-2203

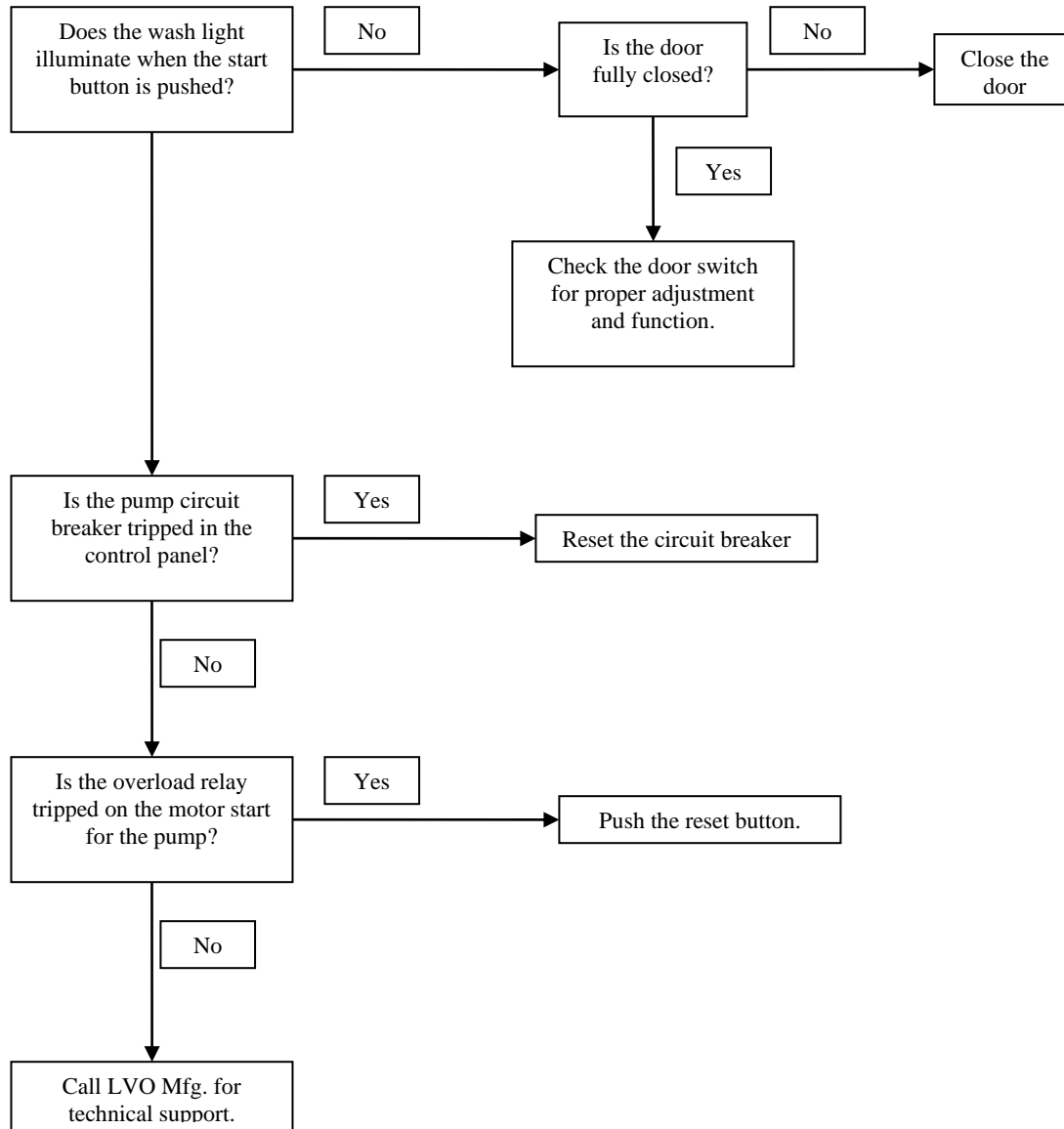



LVO Manufacturing, Inc.

808 N. 2nd Avenue E., P.O. Box 188

Rock Rapids, IA 51246

www.lvomfg.com

(712) 472-3734

1-800-346-5749

Fax (712) 472-2203

Rack Washer Replacement Parts List

RW1548

Miscellaneous Parts

<i><u>Part Number</u></i>	<i><u>Description</u></i>
517-5001	Adjustable Leg
517-5025	Door Latch
517-5026	Door Latch Strike
130-2048	Inside Door Handle Release
517-5024	Door Hinge
130-2025	Pump Screen
130-2023	Center Scrap Tray
130-2024	Side Scrap Tray
130-2047	Rinse Tank – Electric Heat (Threaded Heater)
130-2058	Rinse Tank – Electric Heat (Clamp Heater)
130-2055	Rinse Tank –Steam Heat
512-5011	American Fan with Squirrel Cage
512-5015	Squirrel Cage for American Fan
512-5008	½ Hp Motor for American Fan
130-2056	American Fan Assembly with Motor
517-5011	Rack Caster

Gauge Parts

<i><u>Part Number</u></i>	<i><u>Description</u></i>
509-5153	Temperature Control
509-5133	Temperature Display – Rinse Manifold
509-5155	Temperature Sensor
509-5060	Pressure Gauge, 2 ½”



LVO Manufacturing, Inc.

808 N. 2nd Avenue E., P.O. Box 188

Rock Rapids, IA 51246

www.lvomfg.com

(712) 472-3734

1-800-346-5749 Fax (712) 472-2203

Heating Parts

<u>Part Number</u>	<u>Description</u>
509-5001	Wash Element, 4 ½ kW 208 Volt – Threaded
509-5002	Wash Element, 4 ½ kW 230 Volt – Threaded
509-5003	Wash Element, 4 ½ kW 460 Volt – Threaded
509-5200	Wash Element, 4 ½ kW 208 Volt – Clamp
509-5201	Wash Element, 4 ½ kW 230 Volt – Clamp
509-5204	Wash Element, 4 ½ kW 460 Volt – Clamp
509-5004	Wash & Rinse Element, 9 kW 208 Volt – Threaded
509-5005	Wash & Rinse Element, 9 kW 230 Volt – Threaded
509-5006	Wash & Rinse Element, 9 kW 460 Volt – Threaded
509-5220	Wash & Rinse Element, 9 kW 208 Volt – Clamp
509-5221	Wash & Rinse Element, 9 kW 230 Volt – Clamp
509-5224	Wash & Rinse Element, 9 kW 460 Volt – Clamp
507-5007	2 ½” Sanitary Clamp Gasket for Heaters
507-5001	2 ½” Sanitary Clamp for Heaters
509-5132	High Limit Thermostat
509-5016	Infrared Burner
509-5026	½” Steam Injector – Injected Steam
510-5164	½” Steam Solenoid
509-5050	Direct Spark Ignition Gas Valve
509-5051	Direct Spark Ignition Control Module
509-5052	Spark Igniter
509-5053	Flame Sensor
509-5064	Ignition Cable, 102”
509-5094	5”-7” Gas Regulator Conversion Kit
509-5097	7”-11” Gas Regulator Conversion Kit
511-5127	Sensor Wire
509-5099	LP Gas Orifice, #54
509-5100	Natural Gas Orifice, #45



LVO Manufacturing, Inc.

808 N. 2nd Avenue E., P.O. Box 188

Rock Rapids, IA 51246

www.lvomfg.com

(712) 472-3734

1-800-346-5749

Fax (712) 472-2203

Drain System Parts

Part Number

510-5145

510-5045

510-5214

Description

1 ½" NPT Ball Valve

1 ½" Motorized Ball Valve

1 ½" Motorized Ball Valve w/Manual Override

Wash System Parts

Part Number

103-2025

103-2049

510-5128

510-5129

510-5285

510-5284

510-5102

510-5103

510-5096

510-5092

510-5095

510-5255

510-5254

510-5260

510-5265

510-5271

519-5038

130-2010

Description

Hub Assembly

Hub Repair Kit

5 Hp Pump Motor, 208-230/460 Volt

10 Hp Pump Motor, 208-230/460 Volt

5 Hp Pump & Motor Assembly

10 Hp Pump & Motor Assembly

5 Hp Pump Impeller (Berkeley Pump)

10 Hp Pump Impeller (Berkeley Pump)

Pump Seal Kit (Berkeley Pump)

Pump Motor Shaft Sleeve (Berkeley Pump)

Extension Bracket Gasket (Berkeley Pump)

5 Hp Pump Impeller (Franklin Pump)

10 Hp Pump Impeller (Franklin Pump)

Pump Seal Kit (Franklin Pump)

Pump Motor Shaft Sleeve (Franklin Pump)

Extension Bracket Gasket (Franklin Pump)

Hub Grip Ring Pin

Wash Arm Assembly

Rinse & Fill System Parts

Part Number

510-5011

510-5185

510-5052

510-5009

514-5057

519-5043

519-5027

519-5024

Description

Rinse Nozzle, ¼"

1" 24VAC Solenoid

1" Vacuum Breaker

½" Ball Valve

¾" x 12' Spray Hose

Brass Swivel

Spray Gun

Spray Gun Repair Kit



LVO Manufacturing, Inc.

808 N. 2nd Avenue E., P.O. Box 188

Rock Rapids, IA 51246

www.lvomfg.com

(712) 472-3734

1-800-346-5749 Fax (712) 472-2203

Electrical Parts

<u>Part Number</u>	<u>Description</u>
511-5257	Low Water Cut-Off Float
511-5258	Pit High Water Cut-Off Float
511-5272	On-Off Selector
511-5273	Wash Selector
511-5239	White LED Bulb
511-5214	Clear Indicator Light
511-5215	Amber Indicator Light
511-5216	Red Indicator Light
511-5270	Start Push Button
511-5269	Stop Push Button
511-5271	Auto Fill Push Button
511-5271	Auto Drain Push Button
511-5274	Clear Button Cover
511-5314	24 VAC Logic Controller
511-5338	Circuit Breaker, 4 Amp, 1 Pole
511-5340	Circuit Breaker, 5 Amp, 3 Pole
511-5341	Circuit Breaker, 10 Amp, 3 Pole
511-5342	Circuit Breaker, 15 Amp, 3 Pole
511-5343	Circuit Breaker, 20 Amp, 3 Pole
511-5345	Circuit Breaker, 30 Amp, 3 Pole
511-5347	Circuit Breaker, 40 Amp, 3 Pole
511-5294	Heater Contactor
511-5293	Upper Pump Contactor – 208/230 Volt
511-5291	Upper Pump Contactor – 460 Volt
511-5295	Lower Pump Contactor – 208/230 Volt
511-5293	Lower Pump Contactor – 460 Volt
511-5304	Upper Pump Overload – 208/230 Volt
511-5302	Upper Pump Overload – 460 Volt
511-5307	Lower Pump Overload – 208/230 Volt
511-5304	Lower Pump Overload – 460 Volt
511-5290	Fan Contactor
511-5300	Fan Overload
511-5056	0.250 KVA Control Circuit Transformer
511-5045	Fuse, 2 Amp, 500 Volt
511-5130	Fuse, 3 Amp, 250 Volt
511-5112	Fuse, 4 Amp, 250 Volt
511-5115	Fuse, 5 Amp, 500 Volt
511-5181	Fuse, 12 Amp, 250 Volt

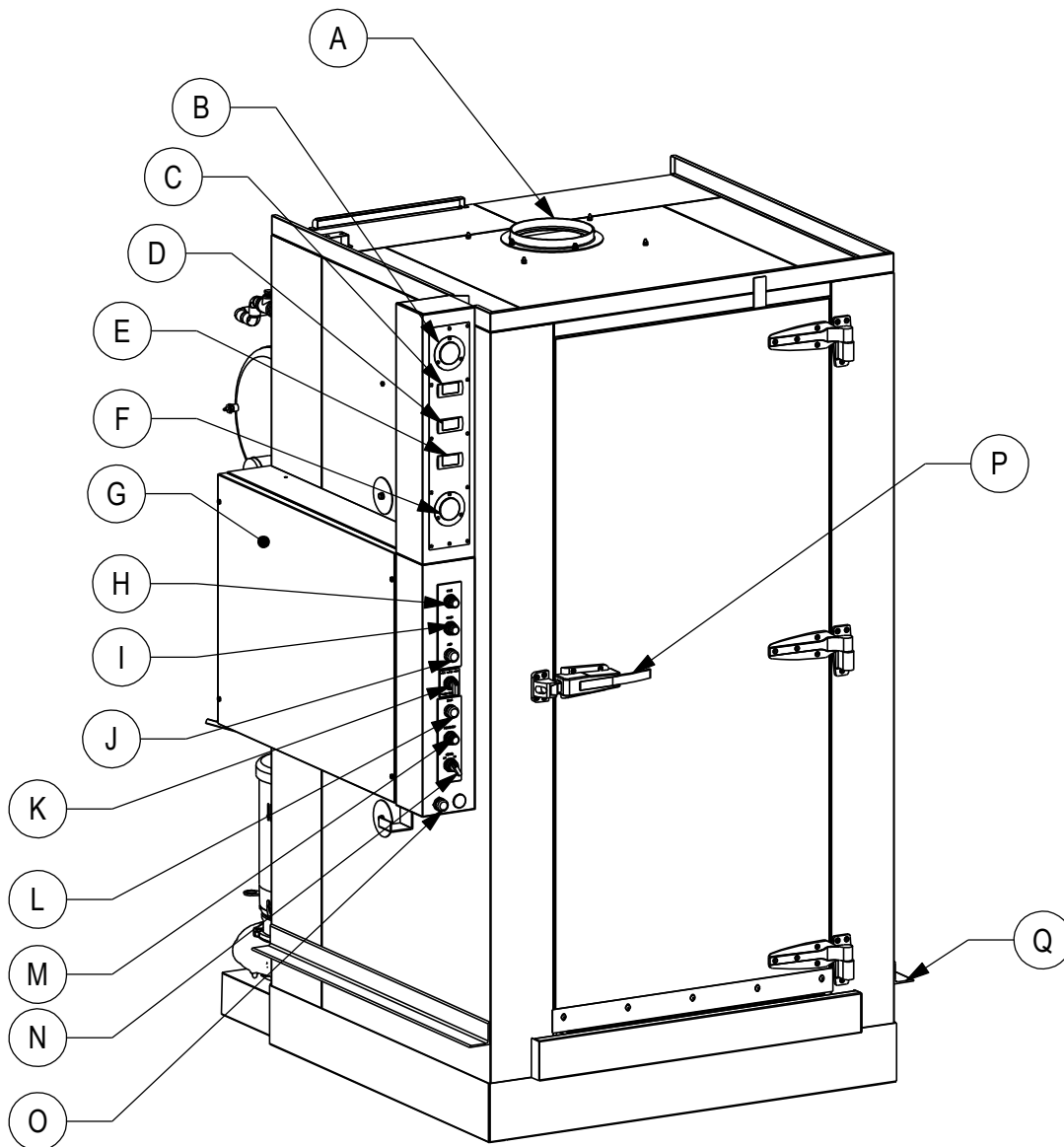

- A. 8" Steam Vent
- B. Rinse Pressure Gauge
- C. Rinse Tank Temp Gauge
- D. Rinse Manifold Temp Gauge
- E. Wash Water Temp Gauge
- F. Wash Pressure Gauge
- G. Control Box Cover
- H. Rinse Cycle Light

- I. Wash Cycle Light
- J. Stop Button
- K. Wash Cycle Selector
- L. Start Button
- M. Power Light
- N. Power Switch
- O. Auto Fill Button
- P. Door Handle
- Q. Pit Support Angle



LVO Manufacturing, Inc.
808 N 2nd Ave E
Rock Rapids, IA 51246

Name: Overview - RW1548

Rev. -

Scale 1:20

1/10/2012

C. Woivood

Phone: (712) 472-3734

Mat. -

Finish -

Ga. -

No. 130-1000-7

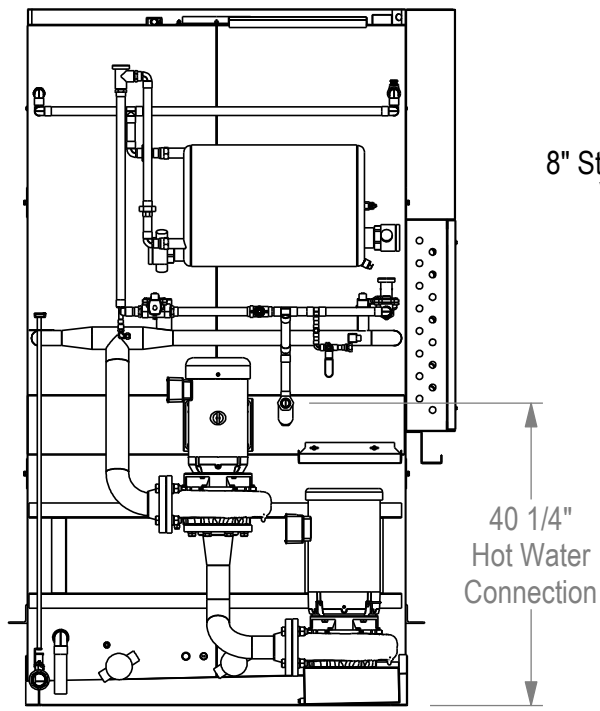

Rear View

8" Steam Vent

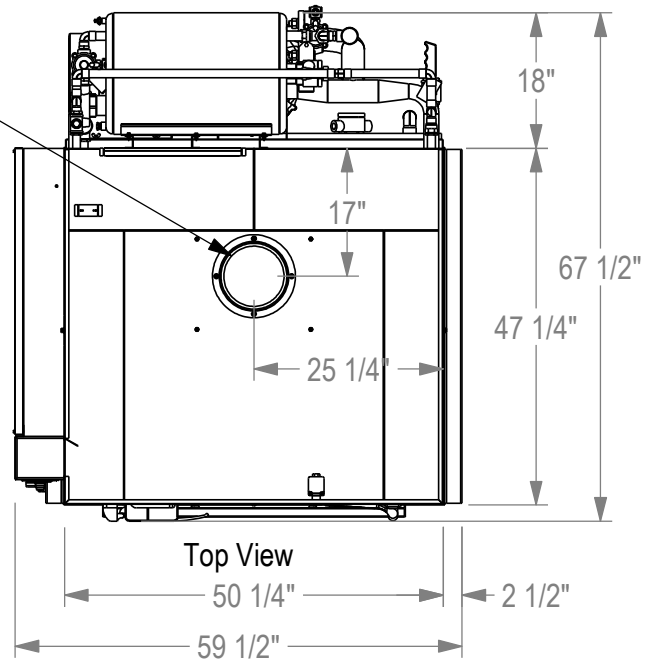

Top View

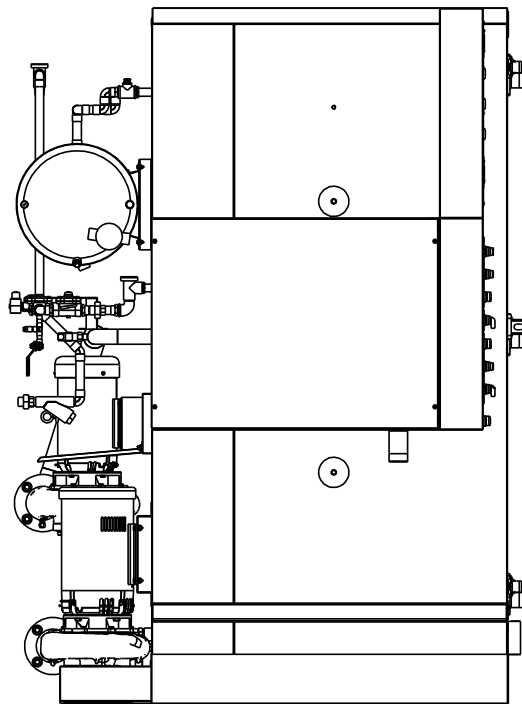

Side View

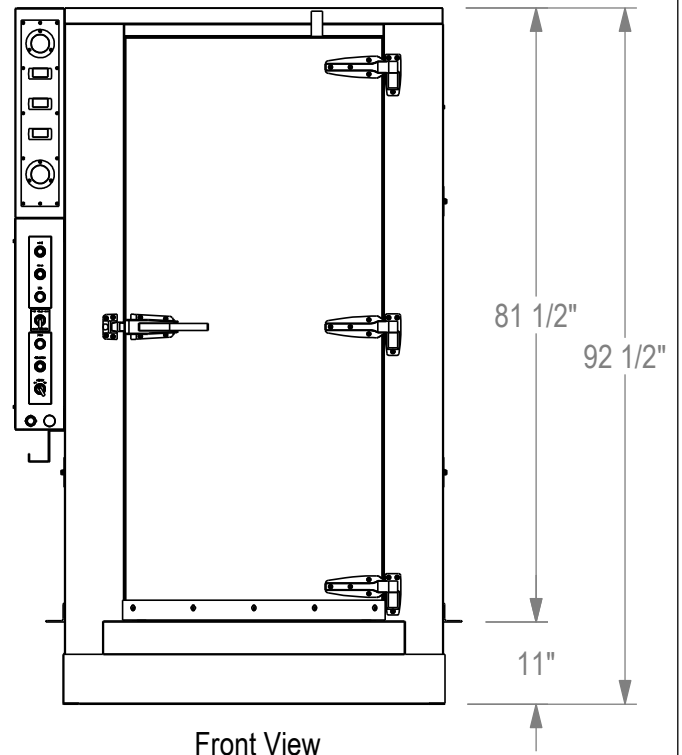

Front View



LVO Manufacturing, Inc.
808 N 2nd Ave E
Rock Rapids, IA 51246

Name: Informative RW1548 Electric

Rev. -

Scale 1:25

1/9/2012

C. Woivood

Mat. -

Finish -

Ga. -

Phone: (712) 472-3734

No. 130-1000-1

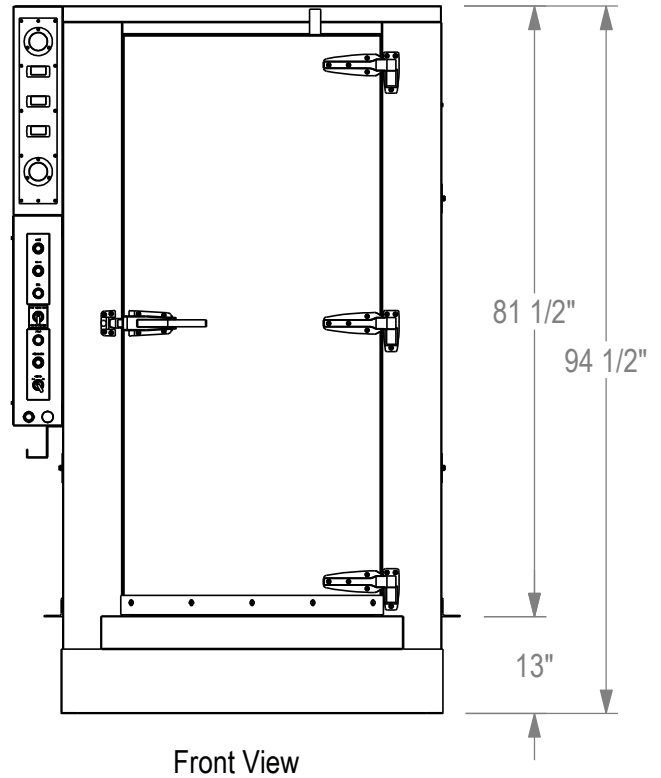
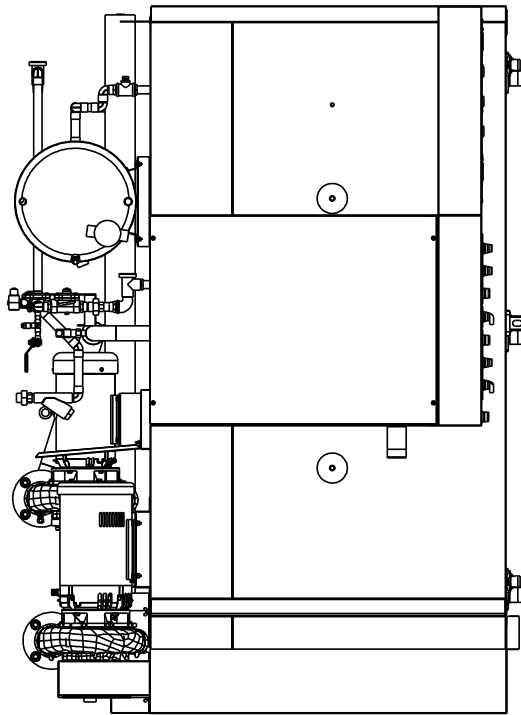
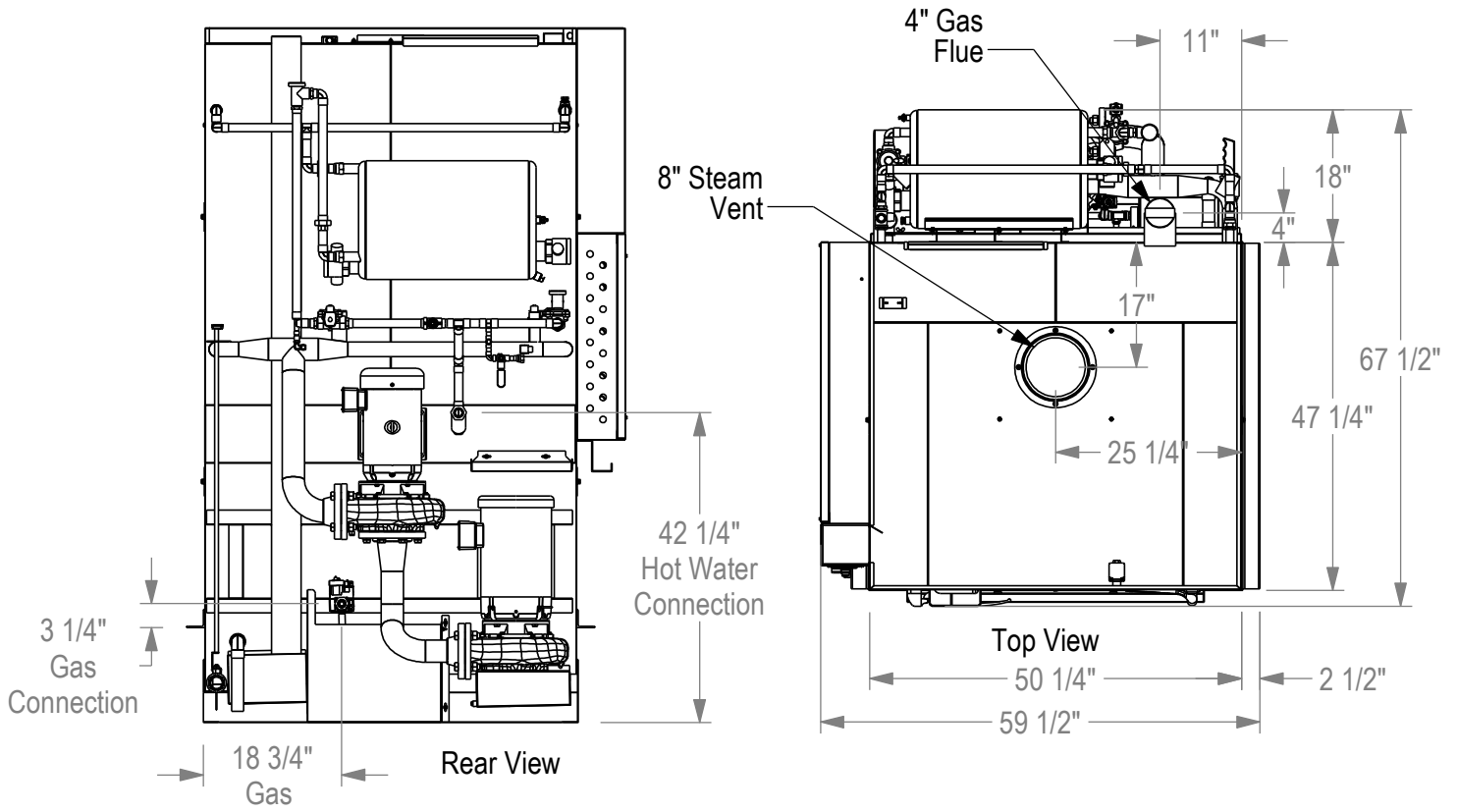

LVO Manufacturing, Inc.
808 N 2nd Ave E
Rock Rapids, IA 51246

Mat. -
Finish -
Rev. -
Phone: (712) 472-3734

Ga. -
Scale 1:25
1/10/2012
C. Woiwood

Name: Informative
RW1548 Gas
No. 130-1100-1

30

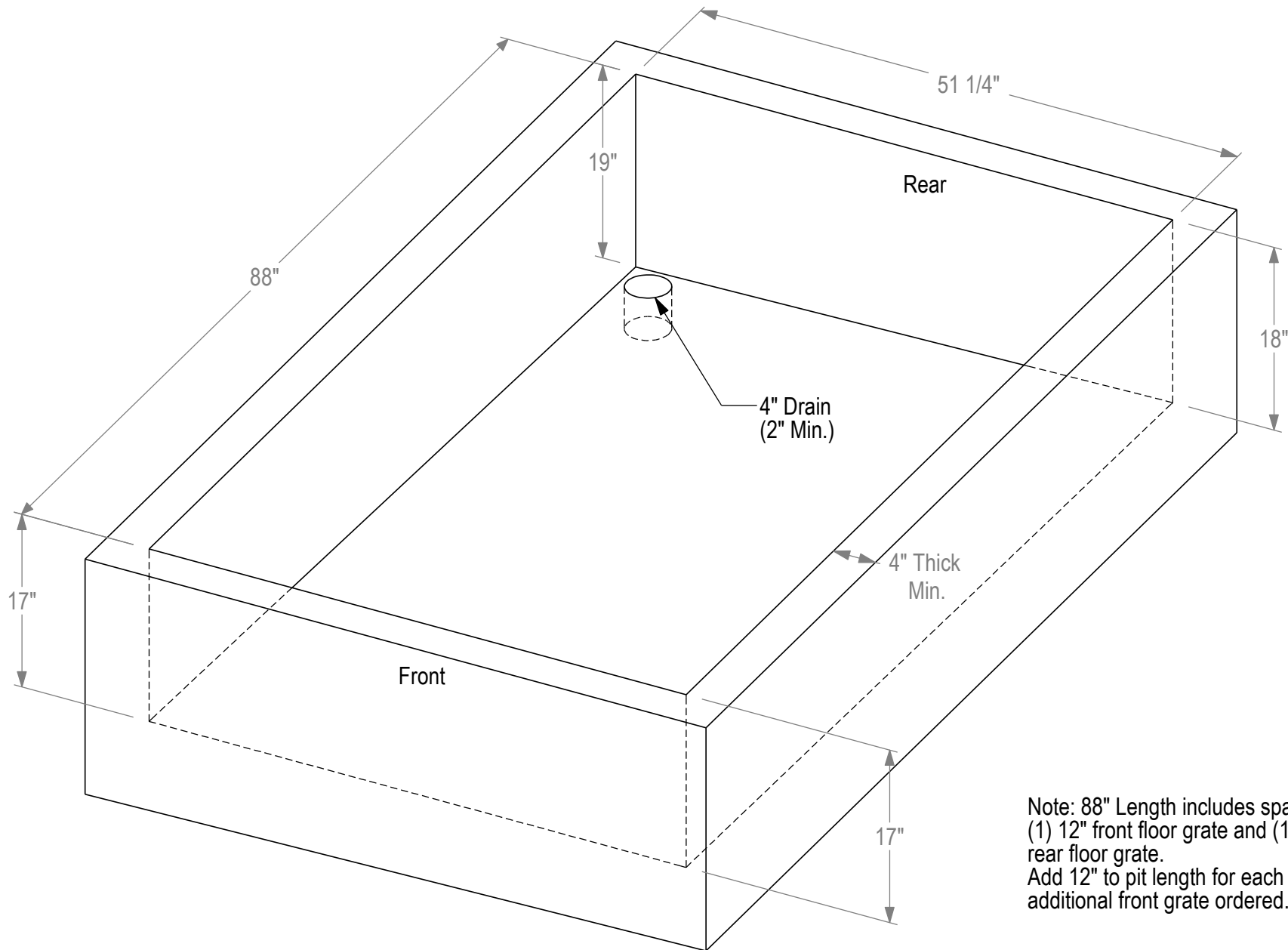

Note: 88" Length includes space for (1) 12" front floor grate and (1) 9" rear floor grate.
 Add 12" to pit length for each additional front grate ordered.



LVO Manufacturing, Inc
 808 N 2nd Ave E
 Rock Rapids, IA 561246
 Phone: (712) 472-3734

Mat. -	
Ga. -	Finish -
Rev. -	

Scale 1:12
9/30/2010
C. Wiowood

Name: Pit Dimensions
-
No. 130-7000

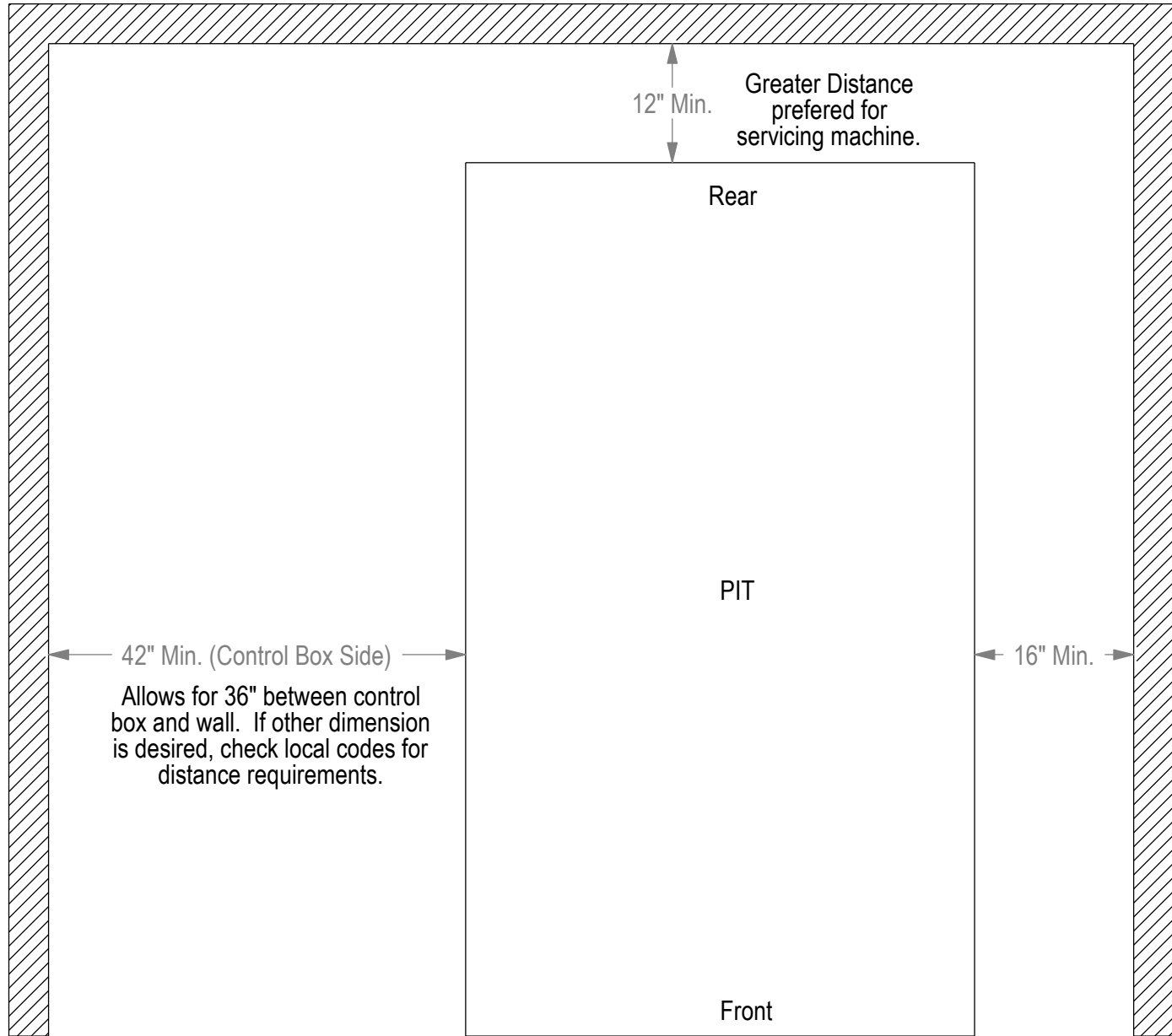

LVO Manufacturing, Inc
 808 N 2nd Ave E
 Rock Rapids, IA 561246
 Phone: (712) 472-3734

Mat. -	
Ga. -	Finish -
Rev. -	

Scale 1:16
9/30/2010
C. Wiowood

Name: Pit Clearance
-
No. 130-7001

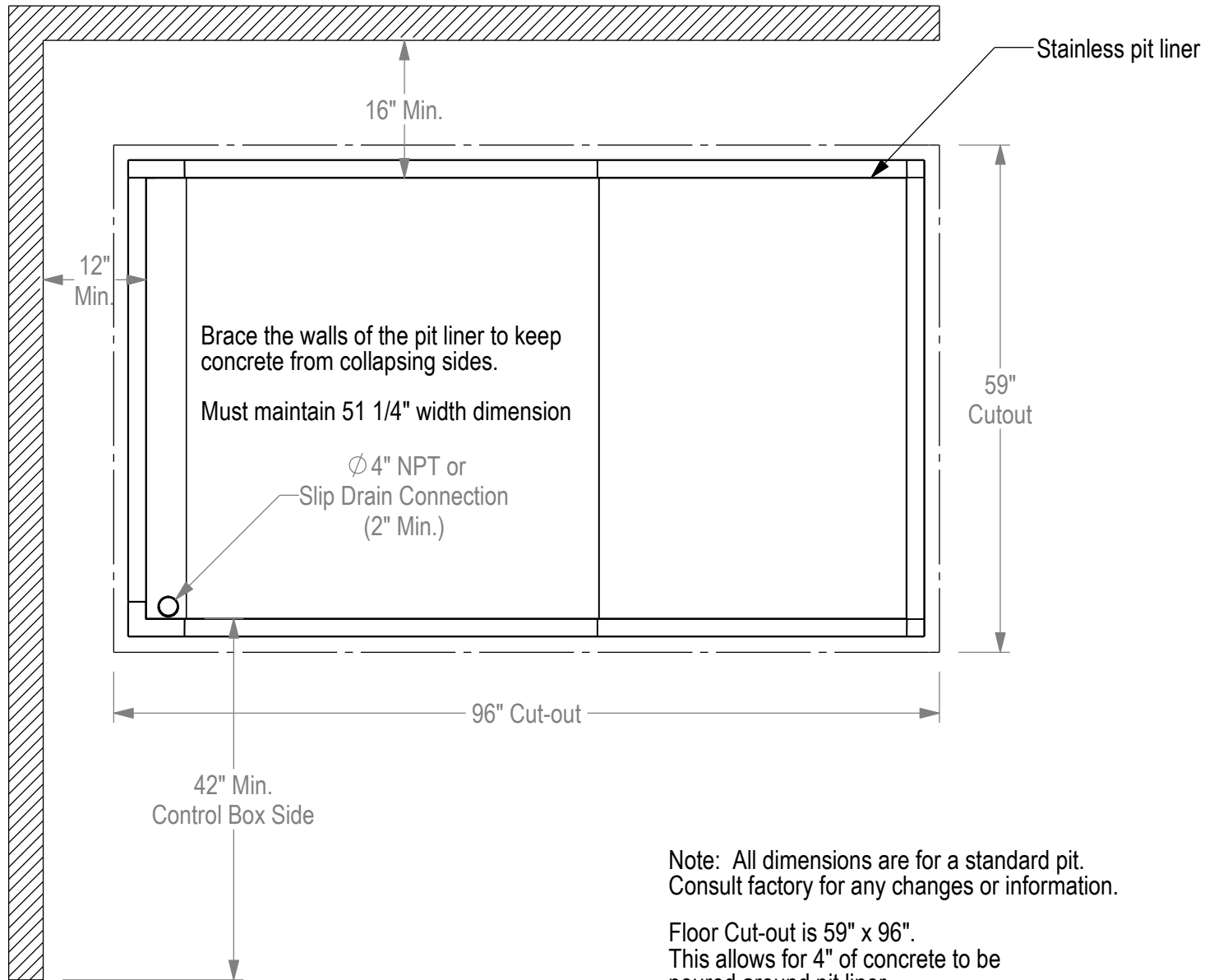

Note: All dimensions are for a standard pit.
Consult factory for any changes or information.

Floor Cut-out is 59" x 96".
This allows for 4" of concrete to be
poured around pit liner.
(Note: Add 12" to length for each additional front grate)



LVO Manufacturing, Inc
808 N 2nd Ave E
Rock Rapids, IA 561246
Phone: (712) 472-3734

Mat. -	
Ga. -	Finish -
Rev. -	

Scale 1:18
1/10/2012
C. Wiowood

Name: Informative
S.S. Pit Liner
No. 130-7002

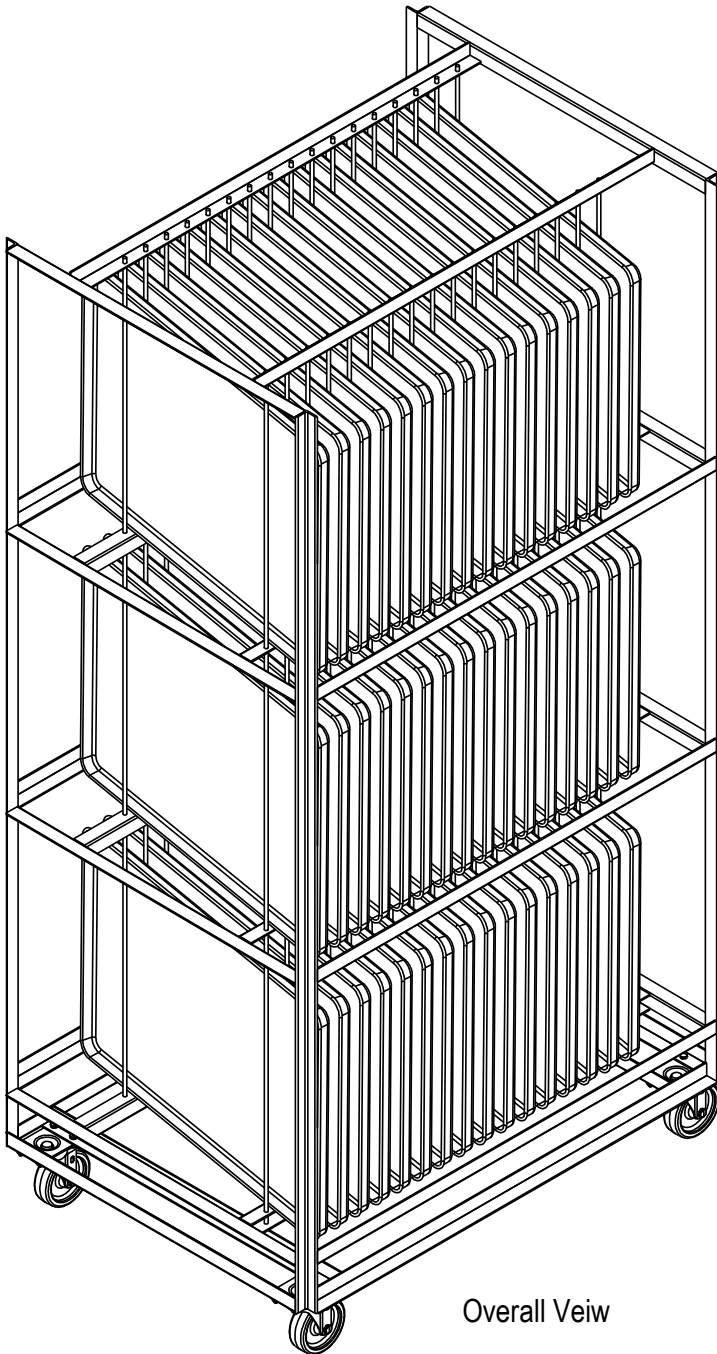

Overall Veiw

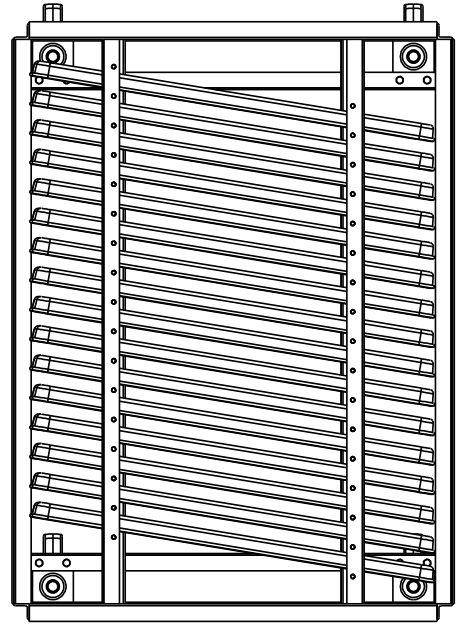

Top View

Note: Load all pans facing same dirrection



LVO Manufacturing, Inc.
808 N 2nd Ave E
Rock Rapids, IA 51246

Mat. -
Finish -
Rev. -
Phone: (712) 472-3734

Ga. -
Scale 1:12
1/10/2012
C. Woiswood

Name: Bun Pan Rack
RW1548
No. 116-2001P

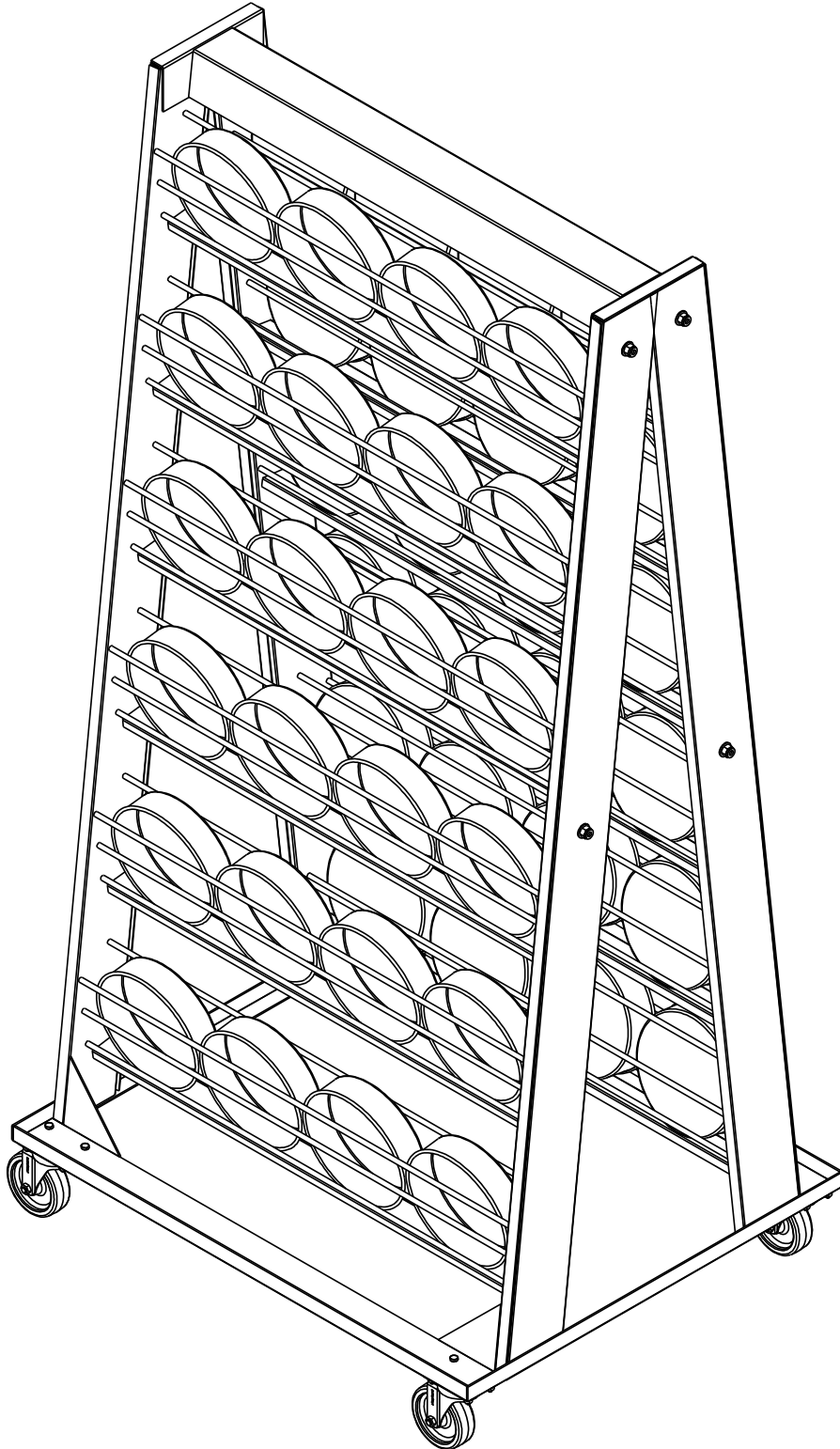

Note: Load all pans facing out



LVO Manufacturing, Inc.
808 N 2nd Ave E
Rock Rapids, IA 51246

Mat. -
Finish -
Rev. -
Phone: (712) 472-3734

Ga. -
Scale 1:10
1/10/2012
C. Woivood

Name: Cake Pan Rack
RW1548
No. 116-2101P

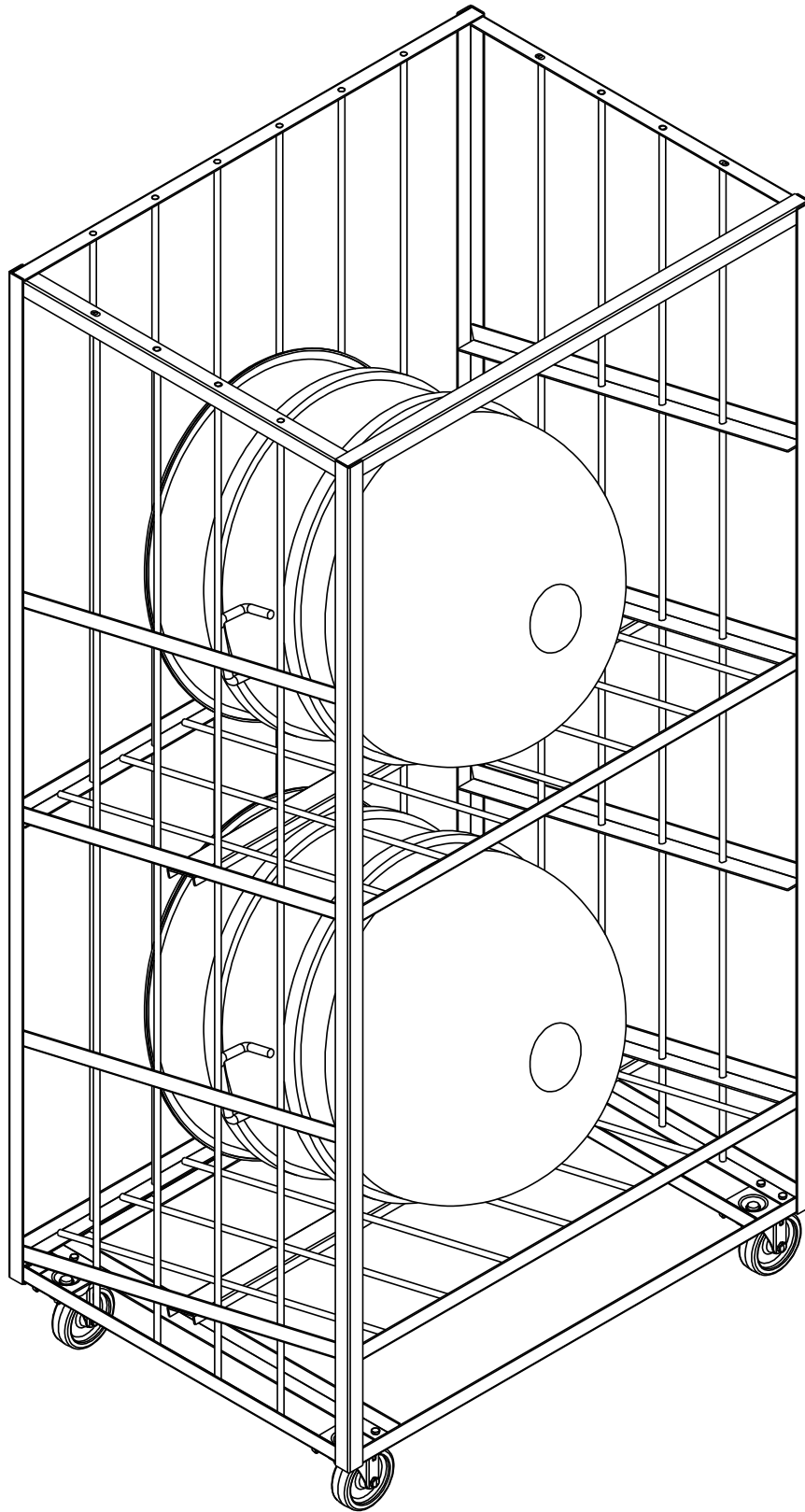

Bowls should be loaded to allow water to drain out.



LVO Manufacturing, Inc.
808 N 2nd Ave E
Rock Rapids, IA 51246

Mat. -

Finish -

Rev. -

Phone: (712) 472-3734

Ga. -

Scale 1:10

1/10/2012

C. Woivood

Name: Bowl Rack

-

No. 116-2201P

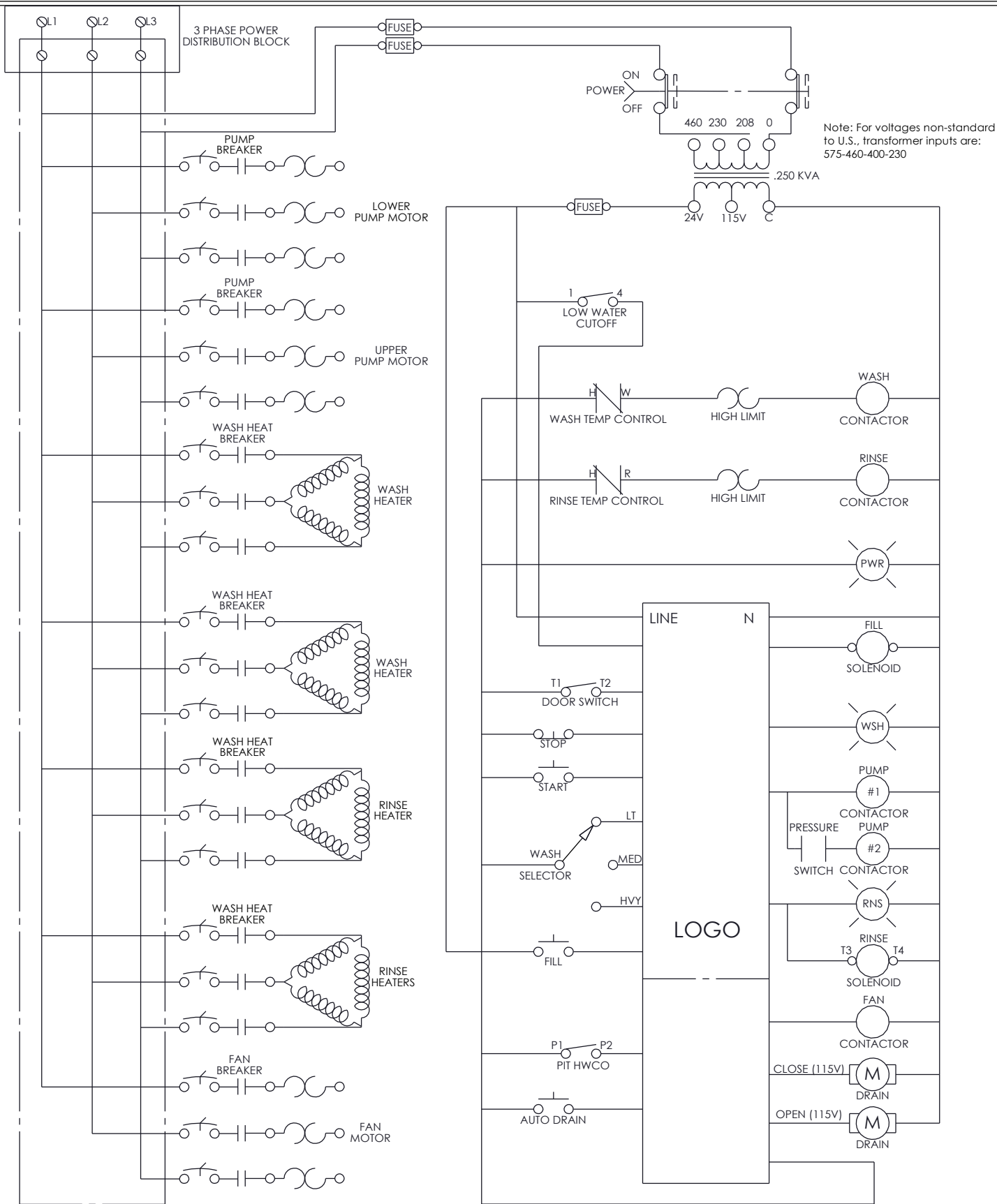

WITH (OPT.) AM FAN, AUTO FILL, AUTO DRAIN, PIT PROTECTION



LVO Manufacturing, Inc.
808 N 2nd Ave E
Rock Rapids, IA 51246

Mat. -
Finish -
Rev. -
Phone: (712) 472-3734

Ga. -
Scale 1:1
1/11/2012
C. Woivood

Name: Ladder Diagram
RW1548 Electric
No. 124L1150

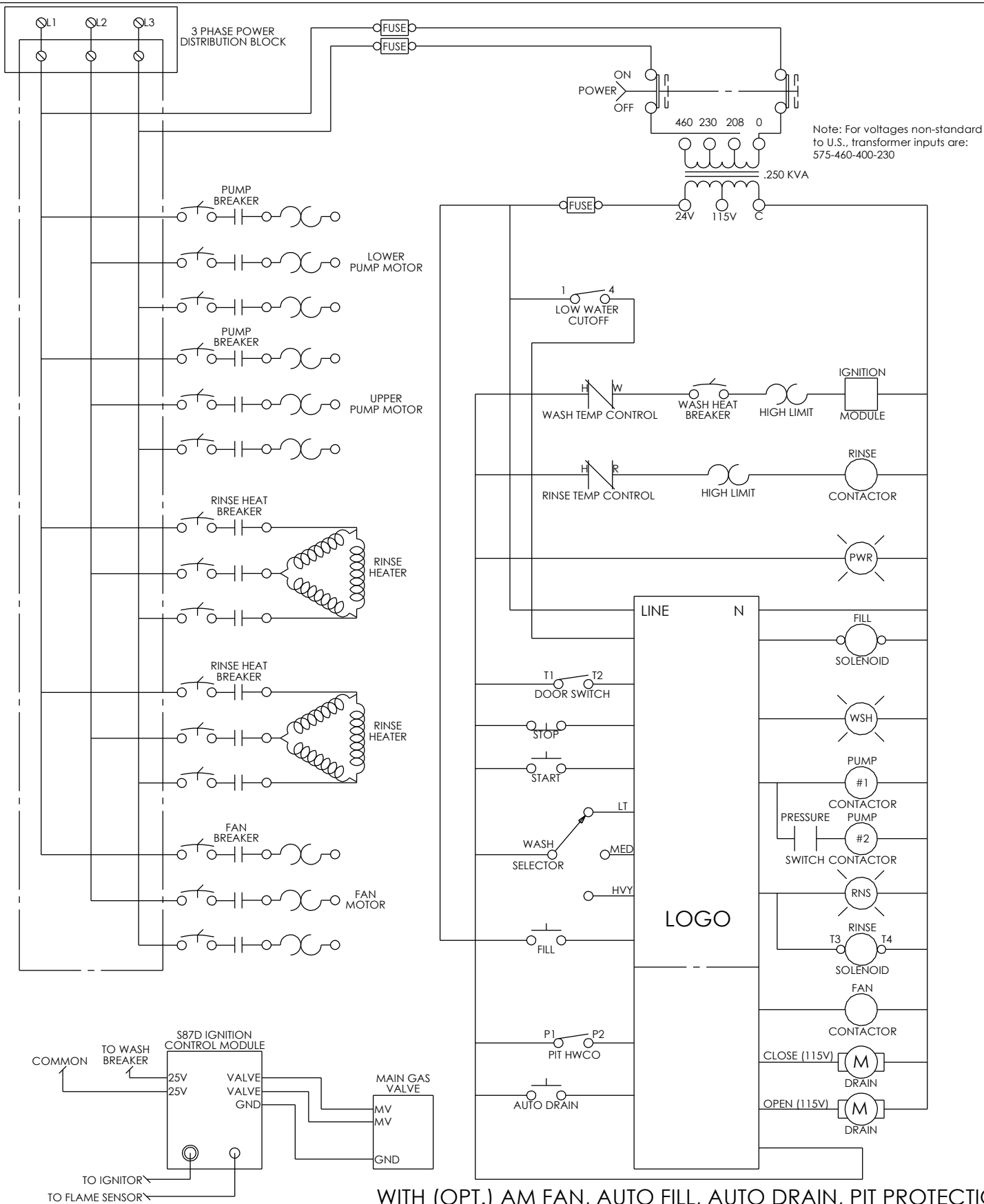

LVO Manufacturing, Inc.
808 N 2nd Ave E
Rock Rapids, IA 51246

Mat. -
Finish -
Rev. -
Phone: (712) 472-3734

Ga. -
Scale 1:1
1/11/2012
C. Woivood

Name: Ladder Diagram
RW1548 Gas
No. 124L1155