

| ITEM | DESCRIPTION | MODEL(S) | PART # (208V/230V) | PART # (460V) |
|------|----------------------|------------------|-----------------------|------------------|
| A | PUMP BREAKER | FL10, PT10, CL10 | 511-5344 | 511-5342 |
| | | FL14, PT14 | 511-5346 | 511-5343 |
| B | WASH HEAT BREAKER | | 511-5338 | |
| C | RINSE HEATER BREAKER | | 511-5347 | 511-5343 |
| D | PUMP CONTACTOR | FL10, PT10, CL10 | 511-5294 | 511-5292 |
| | | FL14, PT14 | 511-5295 | 511-5293 |
| E | GAS CONTROL MODULE | | 509-5051 | |
| F | RINSE HEAT CONTACTOR | | 511-5294 | |
| G | PUMP OVERLOAD | FL10, PT10, CL10 | 511-5305 | 511-5303 |
| | | FL14, PT14 | 511-5307 | 511-5304 |
| H | FAN SPEED CONTROL | | 511-5256 | |
| I | TRANSFORMER | | 511-5056 | |
| J | PRIMARY FUSE | | 511-5130 | 511-5045 |
| K | 115V SECONDARY FUSE | | 511-5074 | |
| L | 24V SECONDARY FUSE | | 511-5207 | |
| M | LOGIC CONTROL | | 511-5314 | |

| Logic Control Inputs | |
|-----------------------|----------------|
| I1 | Float |
| I2 | Door Switch |
| I3 | Stop Button |
| I4 | Start Button |
| I5 | Light Wash |
| I6 | Medium Wash |
| I7 | Heavy Wash |
| I8 | Fill Button |
| Logic Control Outputs | |
| Q1 | Fill Solenoid |
| Q2 | Wash Light |
| Q3 | Pump |
| Q4 | Rinse Solenoid |
| Q5 | Fan |
| Q6 | Low Speed Fan |
| Q8 | LWCO |

| Lower Terminal Blocks | | | |
|-----------------------|-------------------------|-------|-----------------------|
| Soap | To 24VAC Soap Dispenser | 1 | To Float |
| Fan | To Exhaust Fan | W | From Wash High Limit |
| T3 & T4 | To Rinse Solenoid | R | From Rinse High Limit |
| 4 | From Float | C & H | To Temp Controls |
| T1 | To Door Switch | | |
| T2 | From Door Switch | | |
| Fill | To Fill Solenoid | | |
| - | - | | |

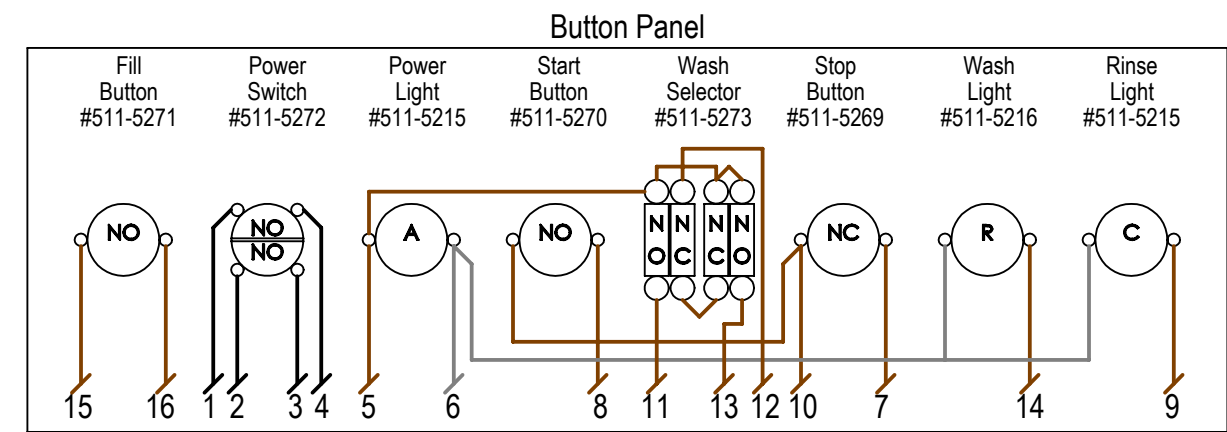

| Fuse Table | | | |
|------------|--------|-------------------|----------|
| Line | 24VAC | 208V/230V Primary | 3 Amp |
| Common | 115VAC | 460V Primary | 2 Amp |
| | | 115V Secondary | 1.25 Amp |
| | | 24V Secondary | 10 Amp |

Name: 10, 14, & 25 Pan Schematic - Gas Heat

LVO Manufacturing, Inc
808 N 2nd Ave E
Rock Rapids, IA 561246
Phone: (712) 472-3734



No. 124-1107A

Rev. -

C. M. Wood

12/29/2014