

ITEM	DESCRIPTION	MODEL(S)	PART # (208V/230V)	PART # (460V)
A	PUMP BREAKER	FL10, PT10, CL10 FL14, PT14 FL25, PT25	511-5344 511-5346	511-5342 511-5343
B	WASH HEAT BREAKER		511-5338	
C	RINSE HEATER BREAKER		511-5347	511-5343
D	FAN BREAKER		511-5340	
E	PUMP CONTACTOR	FL10, PT10, CL10 FL14, PT14 FL25, PT25	511-5294 511-5295	511-5292 511-5293
F	GAS CONTROL MODULE		509-5051	
G	RINSE HEAT CONTACTOR		511-5294	
H	PUMP OVERLOAD	FL10, PT10, CL10 FL14, PT14 FL25, PT25	511-5305 511-5307	511-5303 511-5304
I	FAN RELAY		511-5179	
J	TRANSFORMER		511-5056	
K	PRIMARY FUSE		511-5130	511-5045
L	FAN DRIVE		511-5355	511-5356
M	24V SECONDARY FUSE		511-5207	
N	LOGIC CONTROL		511-5314	

Logic Control Inputs	
I1	Float
I2	Door Switch
I3	Stop Button
I4	Start Button
I5	Light Wash
I6	Medium Wash
I7	Heavy Wash
I8	Fill Button
Logic Control Outputs	
Q2	Wash Light
Q3	Pump
Q4	Rinse/Fill Solenoid
Q5	Fan
Q6	Low Speed Fan
Q8	LWCO

Lower Terminal Blocks			
Soap	To 24VAC Soap Dispenser	1	To Float
T3 & T4	To Rinse/Fill Solenoid	W	From Wash High Limit
4	From Float	R	From Rinse High Limit
		C & H	To Temp Controls
		T1	To Door Switch
		T2	From Door Switch

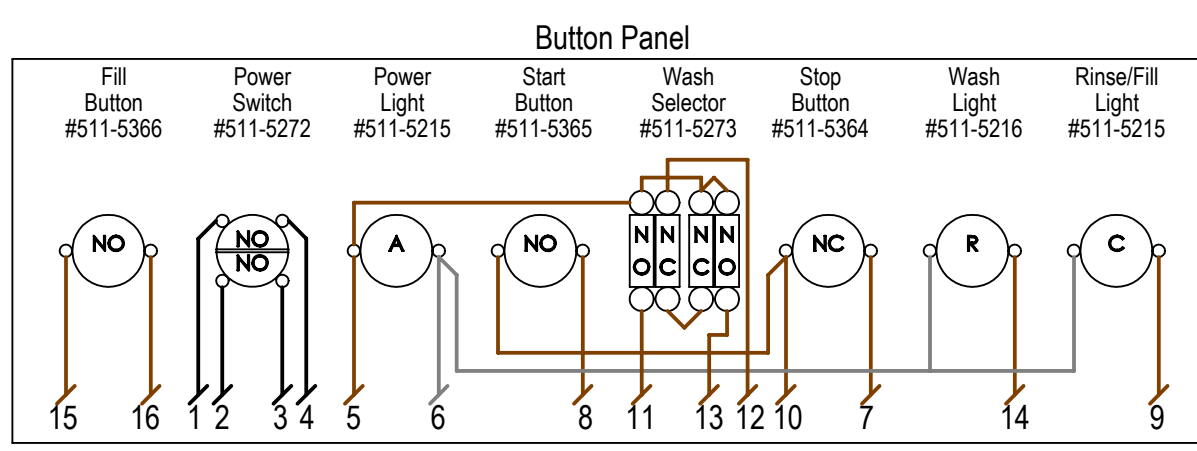

Fuse Table			
Line	24VAC	208V/230V Primary	3 Amp
Common	24VDC	460V Primary	2 Amp
		115V Secondary	1.25 Amp
		24V Secondary	10 Amp

Name: 10, 14, & 25 Pan Schematic - Gas Heat with 3 Phase Variable Speed Fan

LVO Manufacturing, Inc  
808 N 2nd Ave E  
Rock Rapids, IA 561246  
Phone: (712) 472-3734

